

# MINOURA

## indoor bicycle trainer *Live Ride LST9200*

### instructions manual

# KAGURA 神楽

(ver.1.3 2018/5)

#### Applicable Tire Diameter Capacity:

Gravity Mode : 570 – 710mm  
(24-inch – 700x42c)

Fixed Mode : 610 – 710mm  
(26-inch – 700x42c)

Minoura strongly recommend to visit our web site regularly to update the firmware of your own Kagura unit in order to keep your system healthy.

For more info, check out <http://www.minoura.jp/english/trainer/smartturbo/lst9200.html> and click "Firmware Updates" button.

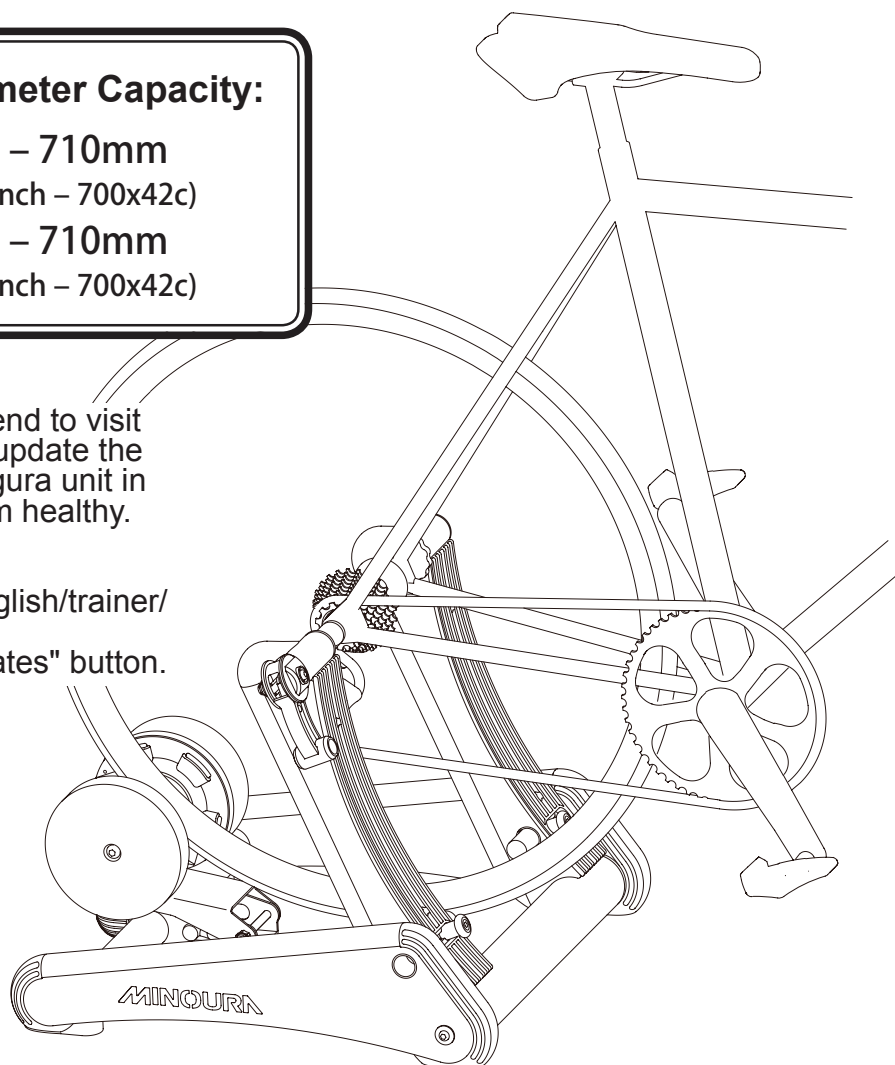

#### Dual Mode

The LST9200 can be used as a gravity trainer or a fixed position trainer by operating the lock lever.

**Fixed Mode** acts like a traditional trainer where the trainer stays in the same position and the rear roller compresses the tire to achieve resistance. This is good for power training.

**Gravity Mode** supports the bicycle frame by the axle allowing the bike to move up and down. Your body weight dictates contact with the roller naturally so no adjustment is needed no matter what bike or tire you use. This also extends tire life.

#### Contact

*If you need support, please first contact the shop you purchased this product from or contact the distributor in your country for assistance. A list of our distributors can be found here: <http://www.minoura.jp/english/support/shop/distributor.html>.*

*If you need further support, contact us at one of the places listed below.*

#### MINOURA North American Tech Center (for U.S. residents ONLY)

Hayward, California, U.S.A.

Phone: 1-510-538-8599 (8 am - 5 pm, Mon - Fri, PST)

Fax: 1-510-538-5899

Email: [support@minourausa.com](mailto:support@minourausa.com)

#### MINOURA Japan Headquarters (for ALL customers)

1197-1 Godo, Anpachi, Gifu 503-2305 Japan

Phone: +81-584-27-3131

Fax: +81-584-27-7505

Email: [minoura@minoura.jp](mailto:minoura@minoura.jp)

Web: [www.minoura.jp](http://www.minoura.jp)

Made in Japan

## Important Notes

Please read carefully before use

- The supplied resistance unit needs to be attached to the frame before use.  
The unit is very heavy and special care must be taken not to drop the unit. Be especially careful of the flywheels (one at each end. One chrome, one black) dropping or otherwise hindering the unit will affect the balance of the unit and void any warranty. Each unit is carefully and fully checked and in full working order prior to being packaged.
- Adjust the roller pressure to the rear tire properly in order to maximize your tire life.  
Tire and roller contact will eventually wear both your tire and the trainer roller.  
Wipe the tire surface to remove any solid dust away before setting the bike on the trainer in order to maximize both the tire and the drive roller life. Minoura recommends adding 10% more air to your tire when training.
- Avoid using your brakes to stop your workout. Let the flywheel come to a stop naturally. Using your brakes will cause damage to the unit and your tire, possibly causing it to burst.
- For use with a normal 2-wheel bicycle only. Do not use a tandem, recumbent, or other.  
Minoura recommends using a completely slick tire when on the trainer. Using a knobby tire will cause premature wear on the unit and your tire.
- Fits rear wheel hub width between 125 and 140mm.  
Hub nut type rear wheel axles are not compatible without replacing the left side coupling bolt (UF-8S) with the optional Left Side Coupling for Hub Nut Axle (UF-8L).
- To use with the 12mm thru axle rear wheel hub, install the optional "Thru Axle Adapter" on your bike frame.  
There are several versions in the adapter depending on the thread pitch size. Choose the appropriate one to your bike frame.
- The trainer is compatible with tire diameter from 570mm–710mm in Gravity mode and from 610mm–710mm in Fixed mode. Any other sizes cannot be used.
- Use the supplied rear quick release skewer for maximum stability. The hub clamping parts (couplings) fits the supplied quick release skewer only. Minoura is not responsible for any problem caused from using your own skewer.
- Be careful not to pinch your finger when raising up or folding down the resistance unit, or folding the frame.
- Touching the spinning wheel and/or any other moving parts while training may cause serious injury.  
Keep children, pets, towel and clothings away from the trainer when in use.
- This product requires electric power souce AC 100 – 240V. Do NOT apply any moisture or mud to the electric magnet unit. Keep clean and avoid any dust even when using indoors.  
If your electric plug shape is different from the supplied one, please use appropriate plug adapter.
- LST9200 has two different resistance systems; the electric magnet and the physical neodymium magnet.  
When using the electric magnet as a smart trainer, adjusting the resistance level can be done only by the wireless control via smart phone or PC. No manual control allowed. Smart phone, tablet, WindowsPC or Macintosh must be set up separately. You must have a dongle device separately when you use on PC or Maintosh. Control applications are not included and are available from third party companies specializing in software applications for SMART trainers.  
Neodymium magnet system (non electric) allows LST9200 to be used without electricity and provides basic resistance for warming up or cooling down.

- LST9200 regularly outputs radio signals. Do NOT use it in the area where any wireless devices are restricted, or near the person who has sensitive devices such as a pacemaker.
- To protect the floor or carpet from stain and sweat during workout, we recommend you to put a sheet or specially designed mat such as the Minoura "TrainingMat4" under the trainer and bike.
- Do NOT use any other AC-adaptor supplied from third parties. Using wrong device could cause unexpected trouble on the Kagura unit such as burning or melting.  
If you hear a strange noise or smell something, stop using LST9200 immediately and contact the retailer where you purchased the trainer. Do not try to disassemble LST9200 without our prior approval.
- Any warranty will be void if you use LST9200 for other purpose than instructed.  
Minoura offers **1-year limited warranty** on this product from the date of your purchase for any problem caused by manufacturer's defect.  
Any damage or problem caused by transporting process or user's misuse, also the natural wear will not be covered under warranty.  
Any damage from shipping or moving must be made to the shipping company.  
Read the enclosed "**Minoura Limited Warranty Policy**" card for more detail.  
For the latest information, refer Minoura web site (<http://www.minoura.jp/english/>).
- Take special care when inserting the power cord into the mag unit. DO NOT force or push the plug in to far. Gently insert the plug until you see the lights on the unit flashing. Then you know it is connected. Pushing the plug too far into the socket on the mag unit will damage the electronics inside the unit and doing so is NOT covered under warranty. There will be a charge for replacement circuit boards or mag units needed due to this issue.

## LST9200 Schematics

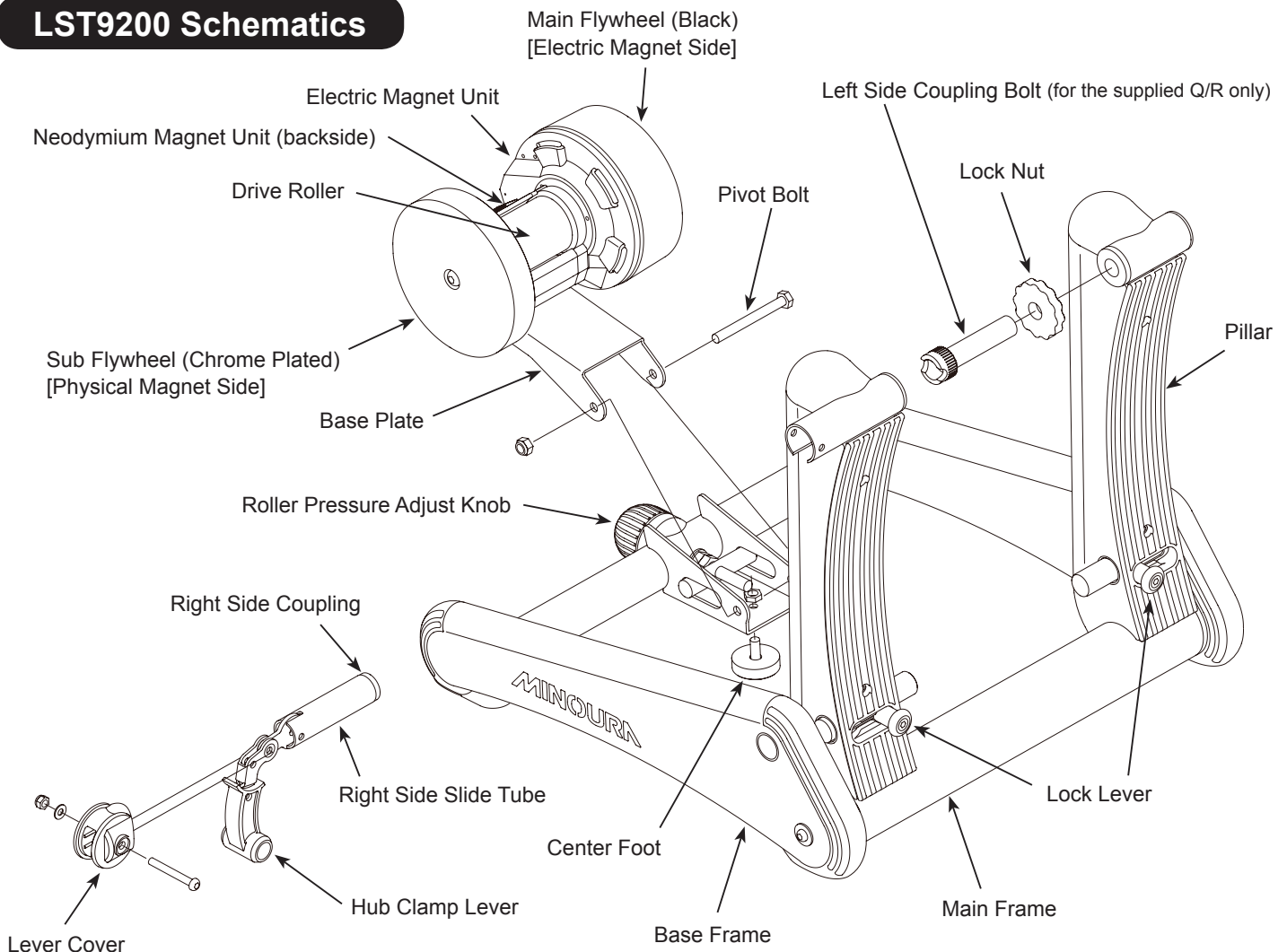

# How To Setup LST9200

**Required Tool : 2 x 13mm open wrench (NOT a closed type)**

The pillars are folded backward in the package. (Fig. A)  
Raise up the pillars and install the resistance unit.

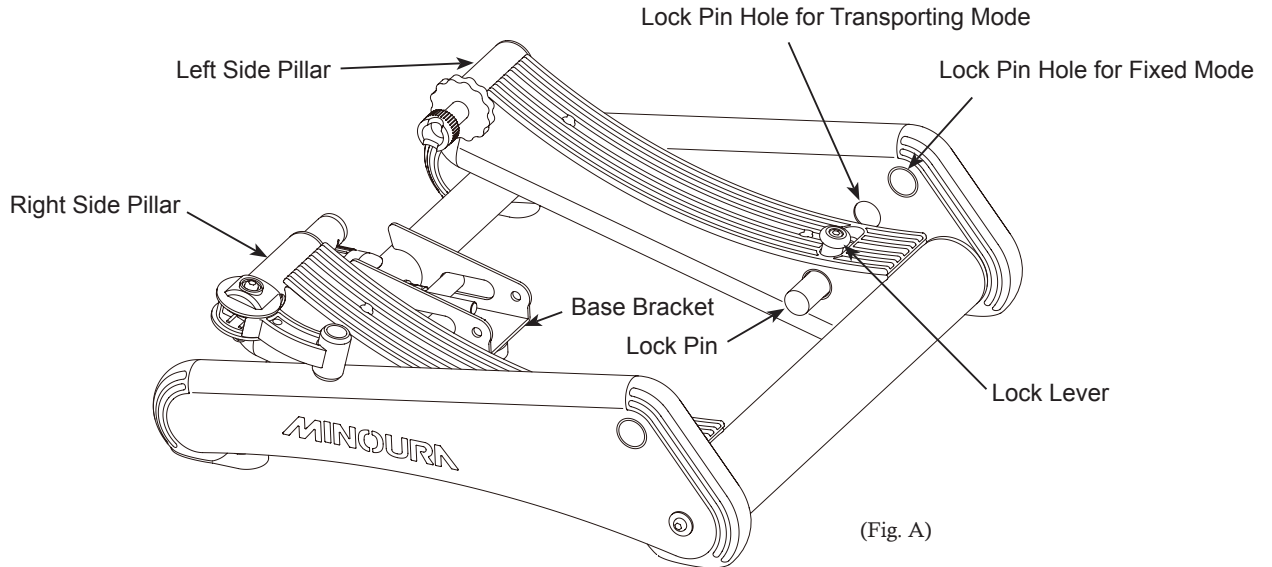

**1**

Make sure both side Lock Levers are released from the holes, then raise up the pillars.

While supporting the pillars, pull the Lock Lever and slide it outward to insert the pin into the hole for Fixed Mode. (Fig. B)

The lever will be retracted by the inside spring. Slide the pin until it's securely locked.

You will do this on both sides to prepare using the trainer in Fixed Mode.

Even if you will choose Gravity Mode, set the pillars in this position first.

**2**

Adjust the center foot length by turning it until all 5 foot points securely touch the floor. (Fig. C)  
If you set the the center foot too high, stability will be compromised.

After adjustment, tighten the inside nut by inserting a 13mm wrench from the front opening.

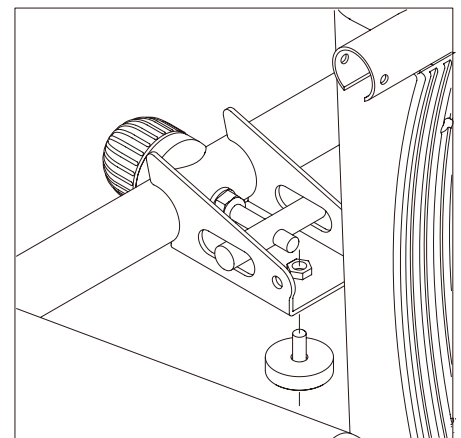
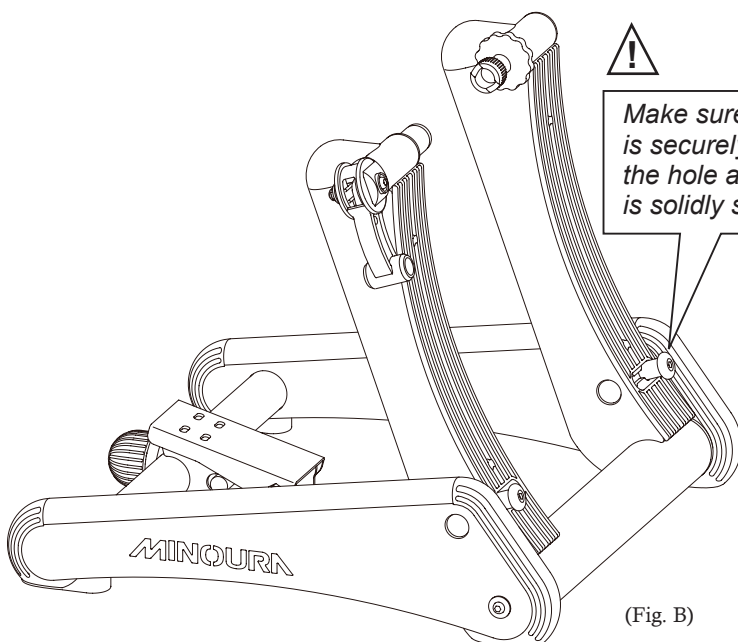

**3**

Take the resistance unit from the box (Fig. D), and install it on the Base Bracket (Fig. E).

Remove the Pivot Bolt and the nut which temporarily set on the Base Plate, put the plate onto the bracket, align the holes, then put the Pivot Bolt into the hole and tighten the nut.

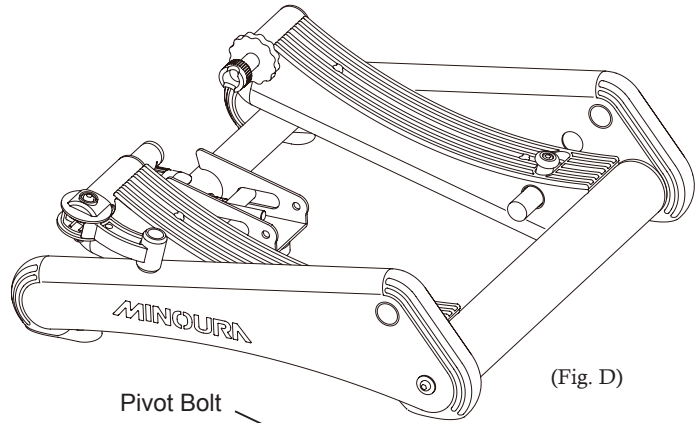
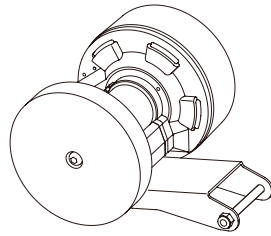

(Fig. D)



*The resistance unit is very heavy. Take care not to drop the unit or pinch your fingers.*



*Over-tightening the pivot bolt will keep the resistance unit from moving freely. Precisely tighten the unit by rotating the knob until the unit moves smoothly with no backlash.*



*The included nut is a Nylon nut and requires a tool to be properly tightened. Do NOT tighten by hand.*

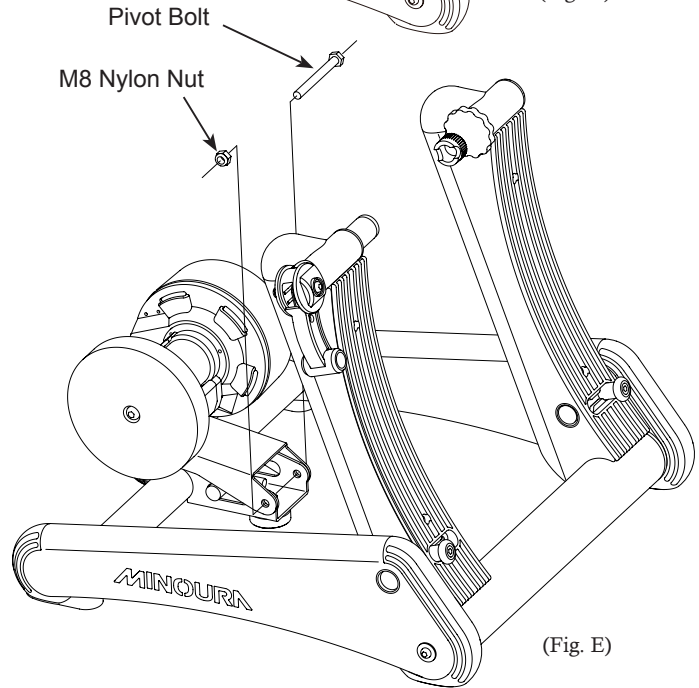

(Fig. E)

## How To Install Rear Wheel

- 1** Turn the Lock Nut counter-clockwise to loosen. (Fig. F-left)
- 2** Left Side Coupling is a screw bolt. Turn it to adjust the length. (Fig. G-left)
- 3** Raise the Hub Clamp Lever up to retract the Right Side Coupling. (Fig. G-right)
- 4** Insert the left side hub end of your bike wheel (quick release lever side) into the left side coupling cone. (Fig. H-left)
- 5** In this position, place the other side of the bike into the right side (rear cog side) coupling cone. Make sure your derailleur cable goes OVER the coupling.
- 6** Now, push down (lower) the Hub Clamp Lever until it fully engages the skewer or axle nut. (Fig. H-right)

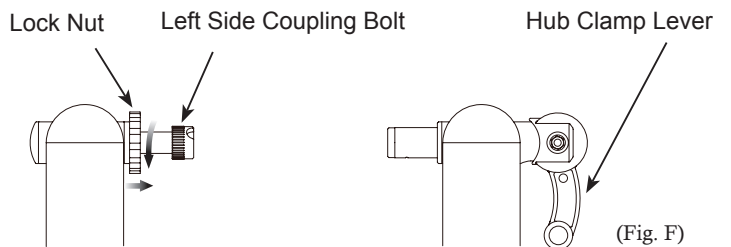

(Fig. F)

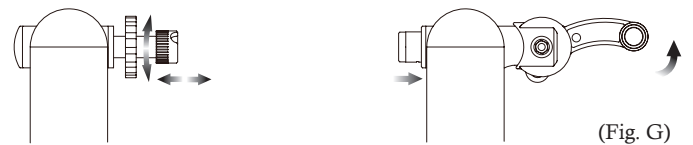

(Fig. G)

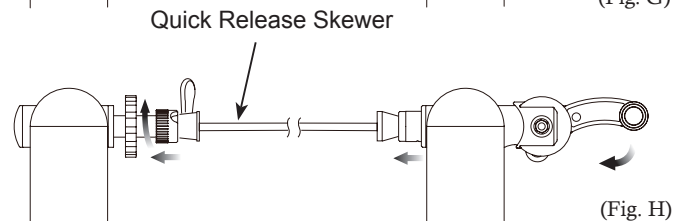

(Fig. H)

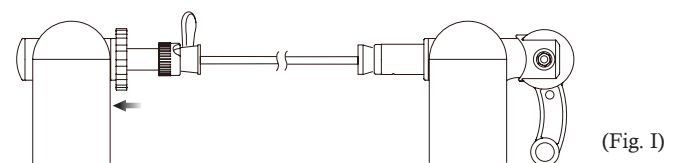

(Fig. I)

**7** Make sure the Hub Clamp Lever is lowered into its locked position and cannot be lowered any further (Fig. I-right). The Main Frame may appear slightly open but this is normal. If the frame seems too big for your bike, or open too wide, remove the bike, turn the Left Side Coupling Bolt clockwise to decrease the width slightly, and mount your bike again. Failure to do so could damage your bike and/or the trainer.

**8** Now, grab the saddle of your bike and rock the bike back and forth to make sure your bike is securely set in the trainer. Your bike should not move independently of the trainer where it is attached.

**9** Tighten the Lock Nut firmly to fix the left side coupling position. (see Fig. I-left)



*If you feel the clamp lever action is too tight, spray a silicon lubricant between the plated right side coupling steel tube and the gray plastic guide sleeve. Do not apply wrong type lubricant, the plastic material could be damaged.*

**10** Make sure the rear tire is positioned as close to the center of the roller as possible, and doesn't touch any other part including the Base Plate. (Fig. J)

You cannot adjust the wheel position by changing the left side coupling bolt length. To do so, loosen the bottom side bolts of the Mag unit then slide the unit side to side. After adjustment, tighten the bolts firmly.

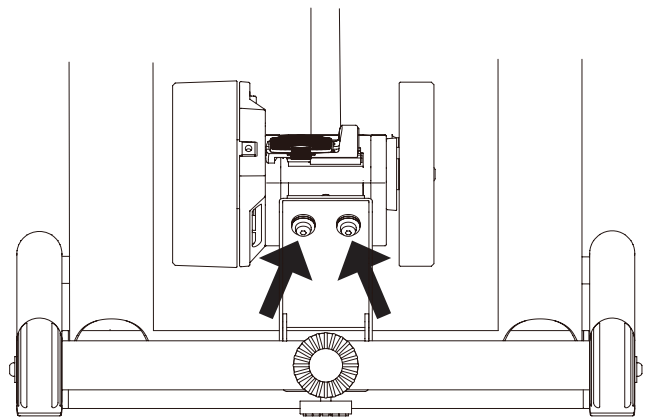

(Fig. J)

## Operating Lock Pin

By moving the Lock Lever, you can engage the Lock Pin into the hole to hold the pillar in the fixed position, or retract the pin to make the pillar free to switch to Gravity Mode.

The Lock Pin can be fixed in two positions; 1) Fixed Mode position and 2) Transporting position. It will move freely when in any other position.

To move the Lock Pin, pull the Lock Lever to release the lock.

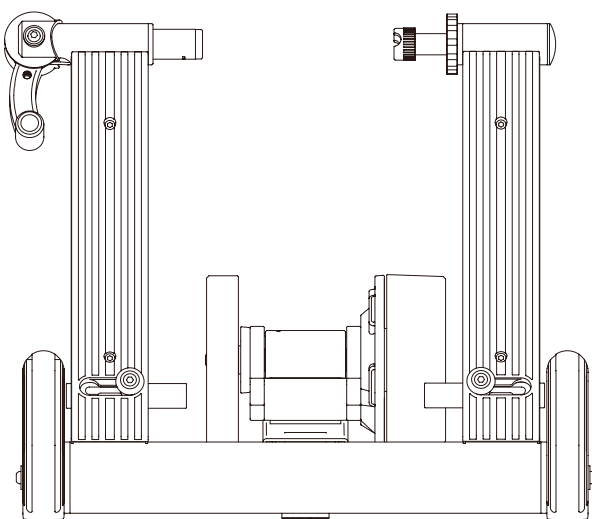

(Fig. K)

[ Retracted Lock Pin = The pillars can move freely ]

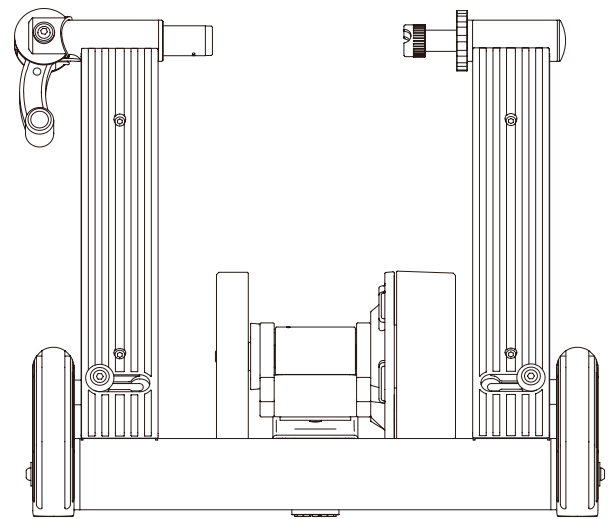

(Fig. L)

[ Inserted Lock Pin = The pillars are securely fixed ]

## How To Use Gravity Mode

In Gravity Mode, the pillars move freely by releasing the Lock Pin from the hole (Fig. M).

The rear tire will be compressed to the drive roller at ideal pressure when applying your own weight including the bike weight automatically and directly.

You don't need to micro adjust the roller pressure every time you set any bike on LST9200 whatever the tire size is. And this also helps extend tire life.

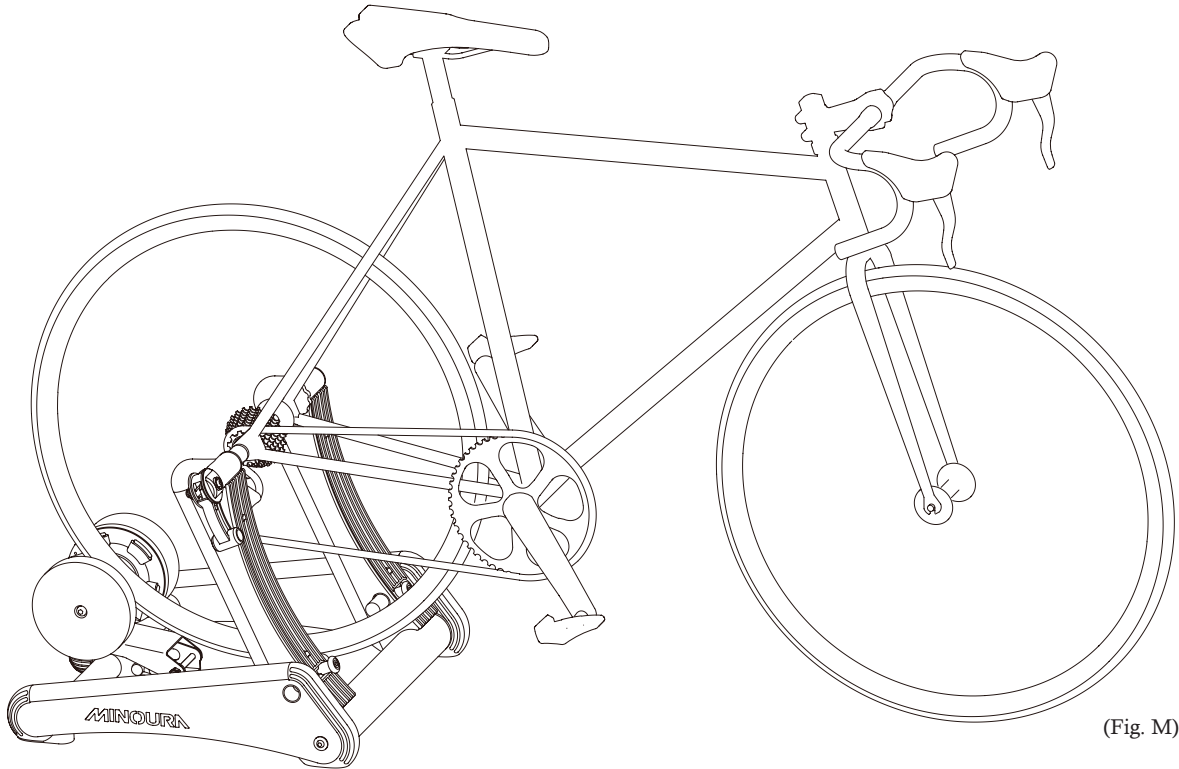

(Fig. M)

- 1** At first, turn the Roller Pressure Adjust Knob clockwise in order to set the Drive Roller at the lowest position.
- 2** Set your bike on the LST9200. The pillars should be securely locked in the Fixed Mode position using the Lock Pins.
- 3** Slide both side Lock Levers inward to release the lock.  
Now the rear wheel will come down due to its own weight, and it stops when it reaches the drive roller.
- 4** Get on the bike and start your workout.



*Please note that the trainers stability will be different than when in Fixed Mode. The trainer will feel less stable. To keep your balance and from possibly falling, stay closer to the bike when getting on/off the bike.*



*In Gravity Mode, the drive roller is not always in contact with the with the rear tire. This is normal depending on your riding style. Sudden movements or out of saddle climbing (dancing on the pedals) could mean loss of contact between the tire and roller. This is to be expected and we recommend staying seated while in Gravity Mode.*

## How To Use Fixed Mode

In Fixed Mode, the bike will be supported at same height level at all times. Even if you apply load to the rear wheel, the wheel position will not change. So you need to push the Drive Roller to the tire.

Correct pressure to the roller is critical. Minoura recommends that the tire compresses 3 – 4mm when properly contacting the roller.

If contact is too weak, periodic slippage will occur between the roller and the tire. It could cause premature tire wear or pit the alloy roller surface unexpectedly.

Too much pressure may cause the tire to burst because of the increased heat being produced.

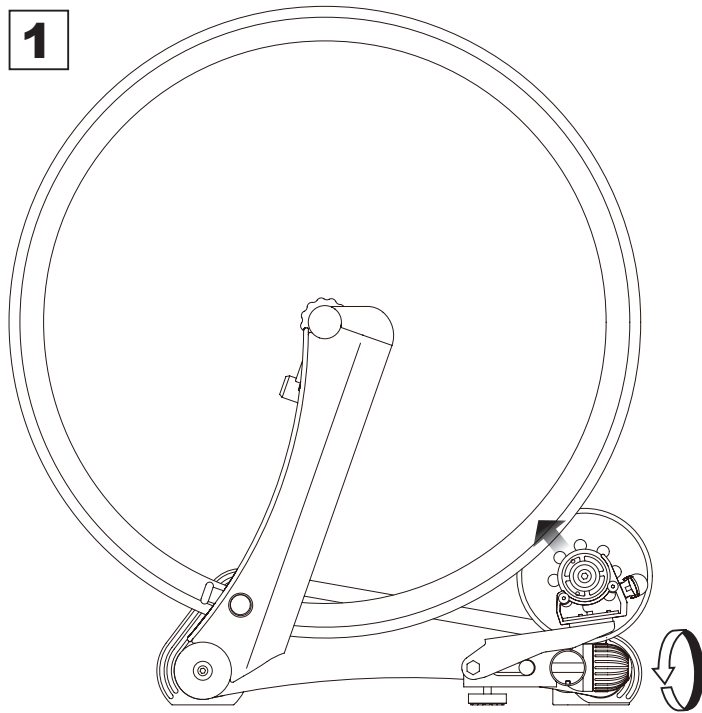

(Fig. N)

Turn the knob counter-clockwise to raise the drive roller up.

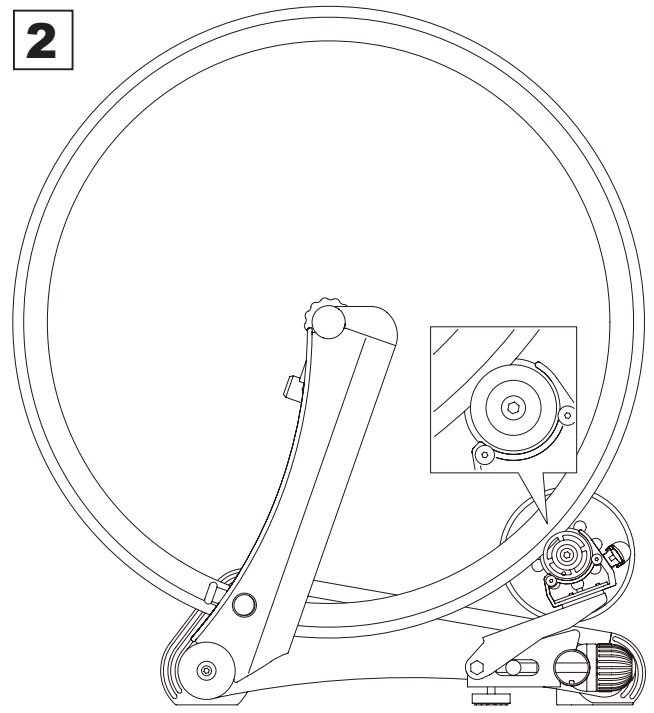

(Fig. O)

Keep turning the knob until the roller compresses the tire in the depth of 3 – 4mm.

**3** When you release the bike from the trainer, turn the knob clockwise to release the tire from the roller.



*When using in Fixed Mode, maintain the tire air pressure 10% higher than usual to achieve longer tire life.*

## Connecting Power Cable & Check

**1** Insert the round side plug into the connecting port behind the Electric Magnet Unit. (Fig. P)



*Do NOT force to push the plug too much. Stop pushing when the plug reached the end. Even it is inserted in the deepest position, the silver part of the plug is still visible, not hidden in the port. If you have pushed the plug too much, the inside circuit panel will have to be damaged seriously. Repairing it will not be covered under warranty.*



- 2** Insert the power cable (not shown in the picture) to the AC Adapter firmly, then connect to the outlet.
- 3** Power turns on automatically. The Red LED will turn on, and the Blue LED will be blinking. (Fig. Q)
- 4** To turn off the power, simply remove the power cable from the outlet, or gently remove the plug from the port (do not grab the wire). Both LEDs will turn off.
- 5** You can see the current status of the wireless connection with the LED patterns as shown in Fig. R. The blinking red LED means the resistance power is increasing.

**!** Do not hook and pull the power cable strongly (especially sideward). It will cause a serious problem to the circuit board. Repairing it will not be covered under warranty.

**!** Minoura does not supply instructions on how to connect or pair your trainer with your chosen training app. Please refer to the app for instructions on how to connect the trainer for use with any given app.

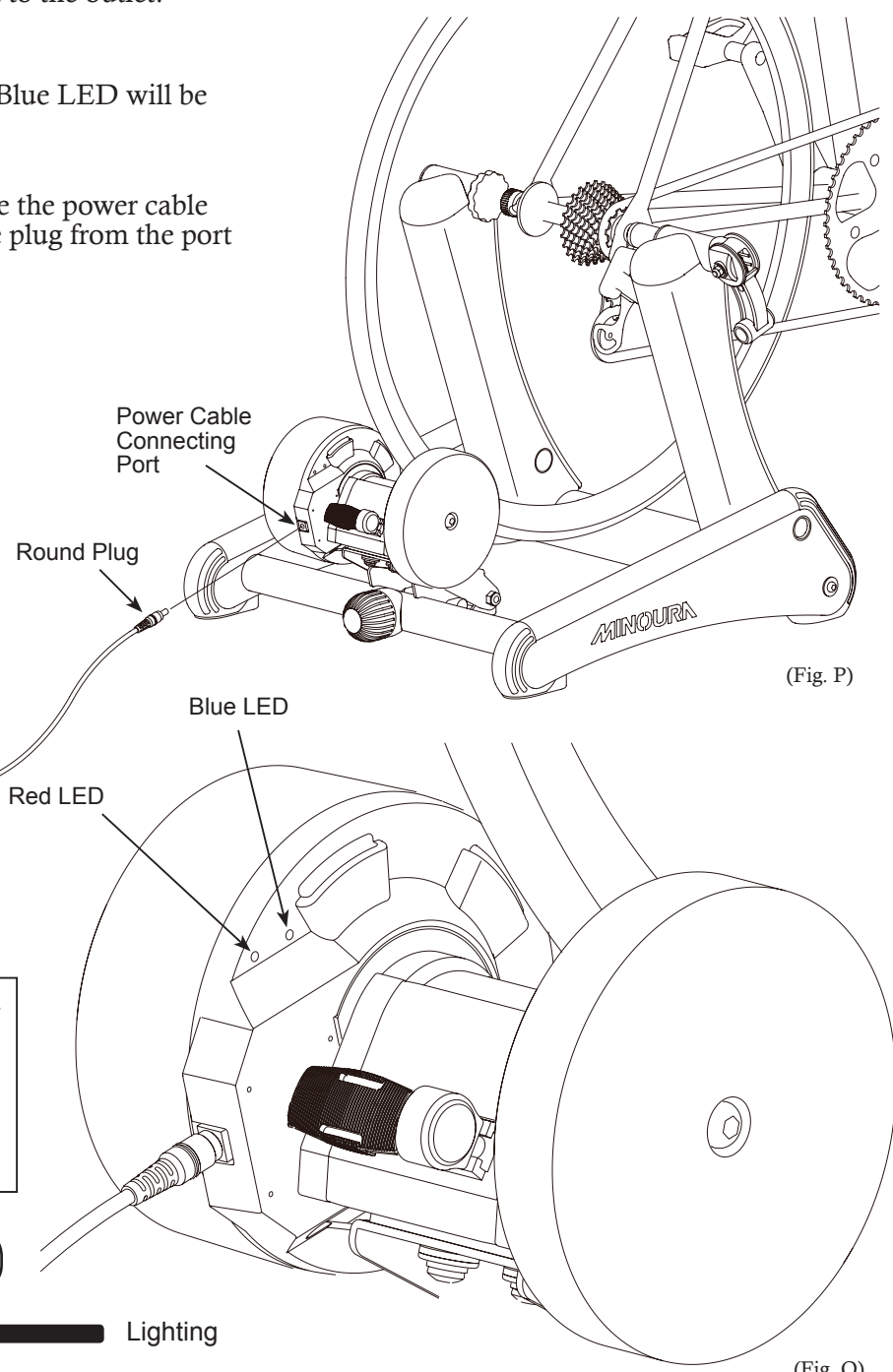

(Fig. P)

(Fig. Q)

### LED Patterns & Meanings

	● ● ● ● ● Blinking	█ Lighting	
Blue LED ● ● ● ● ● Red LED █			Power is ON. Awaiting pairing process
Blue LED █ Red LED █			Connected via Bluetooth. The connection has been completed (Blue LED changes from blinking to solid)
Blue LED █ Red LED ● ● ● ● ●			Connected via Bluetooth, and the electric power is increasing
Blue LED ● ● ● ● ● Red LED █			Connecting via ANT+ is completed (Blue LED is still blinking. Optional ANT+ receiver is required for this connection. Refer the application screen about the connecting status)

(Fig. R)

## How To Use Neodymium Magnet

The red lever is for sliding the neodymium magnet to generate resistance between the magnet and the steel flywheel.

It does not require any electric power so it allows to use outdoors as same as the stationary trainer.

4 levels are available. Good for light training sessions, warming up or cooling down, or daily exercise.

To use it, slide the magnet unit while pushing down the red lever. Set the lever in the fixed position. The closer the magnet is to the flywheel, the more the resistance power.

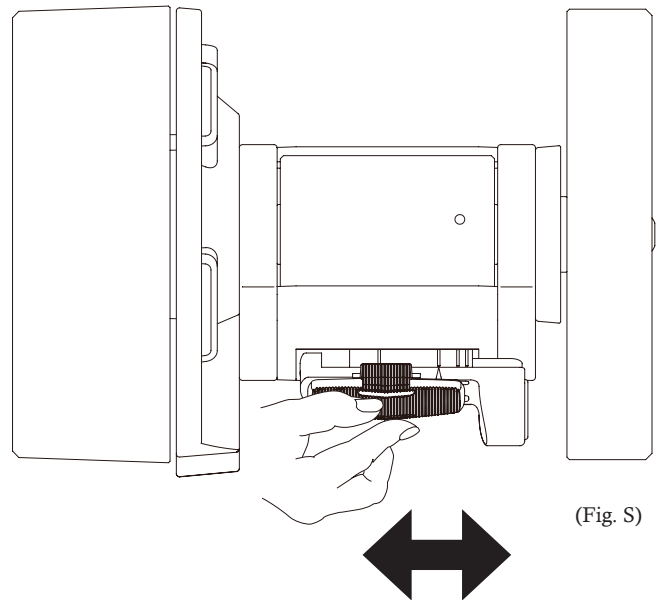

(Fig. S)

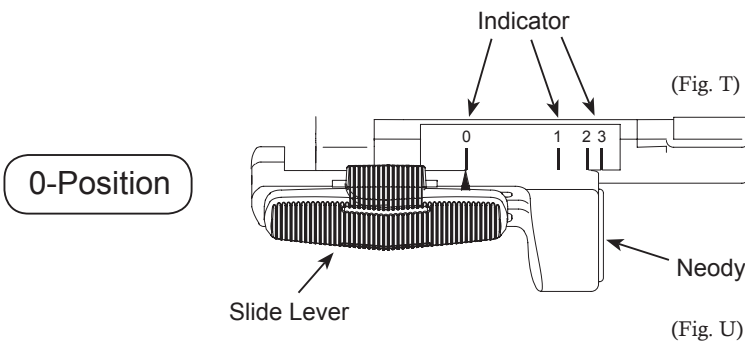

(Fig. T)

Load Level : **Few** (not Zero)

Magnet sits in the farthest position from the flywheel.

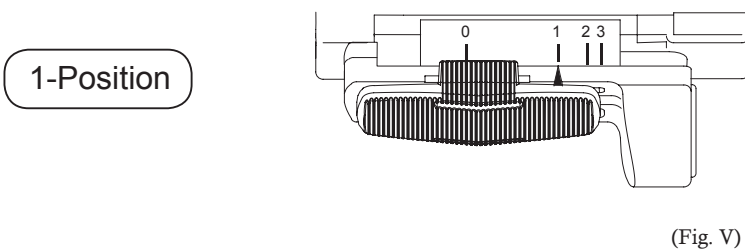

(Fig. U)

Load Level : **Approx. 100W** (@ 40 km/h) ※

Magnet is 1 step closer to the flywheel.

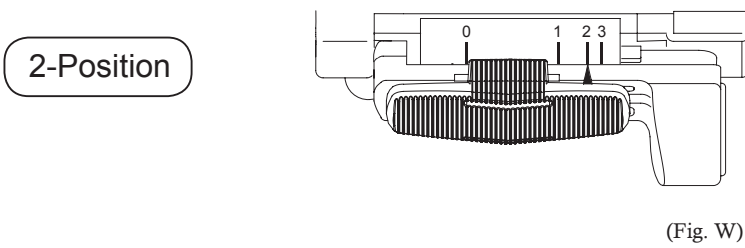

(Fig. V)

Load Level : **Approx. 200W** (@ 40 km/h) ※

Magnet is 2 steps closer to the flywheel.

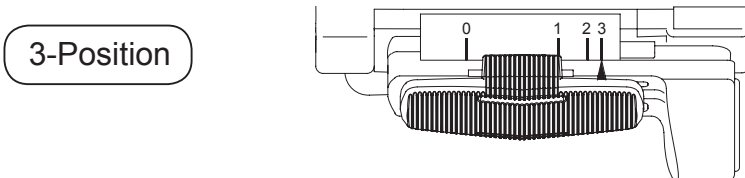

(Fig. W)

Load Level : **Approx. 300W** (@ 40 km/h) ※

Magnet is in the closest position to the flywheel.



*Do the power adjustment AFTER the wheel stops completely.*



*Be careful not to pinch your finger between the magnet and the flywheel.*



*Confirm before using if the neodymium magnet surface is clean.*



*Set the magnet at the 0-position when you use LST9200 as a smart trainer.*

※

Power data is not guaranteed accurate and could vary.