

MINOURA

MagTurbo DirectDrive MD640

Magnetic Resistance Type Bicycle Indoor Trainer

Instructions Manual

(ver.1.0 2021/10)

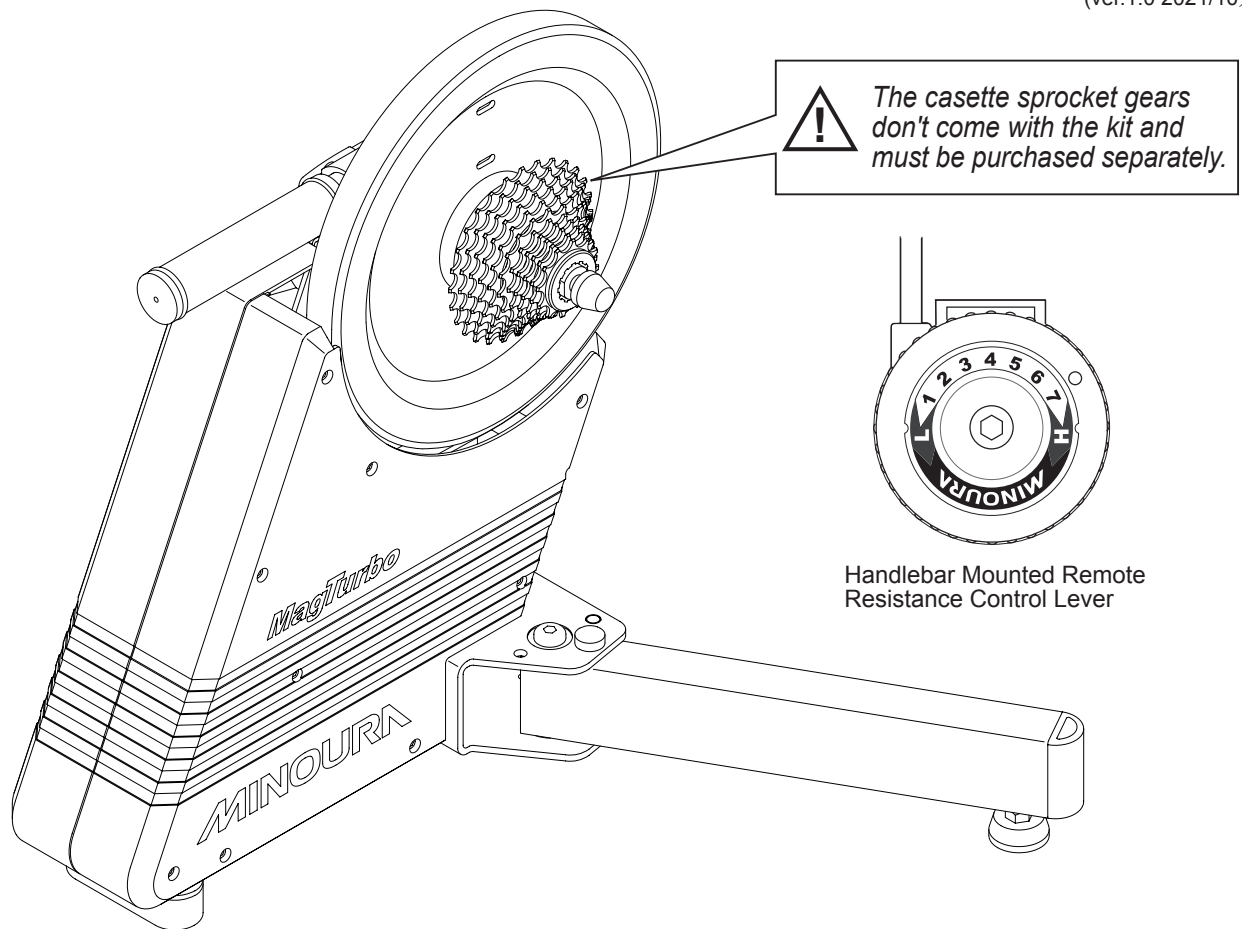

Merit of Direct Drive

The MD640 Direct-Drive works with your current bike frame when you remove your wheel and mount your frame directly to the unit. Direct-Drive eliminates any potential power loss from traditional trainers because there is no chance of tire slippage and it transmits all the power you generate to the magnetic resistance unit.

Permanent Magnet Unit

The resistance unit on MD640 is based on permanent magnet that doesn't require any electric power to be driven. It provides wide variety of resistance levels from low to high, and it can be controlled via the handlebar mounted 13 position Remote Shifter.

Compatibility

The MD640 is compatible with **Shimano** and **SRAM 8s, 9s, 10s and 11s**, and also **12s on SRAM**. SRAM XD/XDR requires the optional adapter (a special free hub). Campagnolo is currently NOT supported. You need to prepare the rear sprocket gear that fits your bike component. Also the 9mm Quick Release Skewer doesn't come with the kit. Use your own one.

Contact

If you have any trouble with this product or request for maintenance, refer the attached "Minoura Limited Warranty Policy" card first, then contact the shop you originally purchased this product or the distributor in your country. The distributor list is found on our web site.

MINOURA North American Tech Center (for U.S. residents ONLY)

Hayward, California, U.S.A.

Phone: 1-510-538-8599 (8 am - 5 pm, Mon - Fri, PST)

Fax: 1-510-538-5899

Email: support@minourausa.com

MINOURA Japan Headquarters (for ALL customers)

134-1 Shimomiya, Godo, Anpachi, Gifu 503-2312 Japan

Fax: +81-584-27-7505

Email: minoura@minoura.jp

Web: www.minoura.jp

Made in Japan

- Compatible only with the rear wheel hub width 130 & 135mm in 9mm Quick Release system, or 142 & 148mm in 12mm Thru Axle system. Any other sizes or systems are not compatible.
- The 9mm quick release skewer doesn't come with the kit. Your bike may already use one. Direct Mount systems may require a more durable skewer. A weak Quick Release may break in use due to the direct-mount mechanism design. Consider purchasing an extra skewer.
- Compatible with Shimano and SRAM (except XD / XDR) 8s, 9s, 10s and 11s gears, in addition 12s on SRAM. Campagnolo is NOT compatible at this moment.
The sprocket gear does NOT come in the kit so you need to prepare it separately.
- Shift the rear derailleur to the top before removing the rear wheel to make the set-up process easier.
- Fully open the legs and place on flat and horizontal floor. Adjust all 2 foot adjusters correctly to set the bike vertical and level.
- Do not touch the spinning flywheel, belt or chain while training. This could cause serious injury or burns.
- Make sure you assemble the quick release skewer or the thru axle correctly when installing the bike to the trainer. If it becomes loose, the bike may come off while using.
- The MD640 is a precisely manufactured, especially on the big flywheel unit. Misuse or abuse of the product may cause the unit to malfunction which will not be covered under the warranty.
There are NO user serviceable parts on MD640. Disassembling the product in any way will immediately void any warranty.
- When closing the legs for storage or transportation, be careful not to pinch your finger. Screw the knob bolts which holds the legs to the certain hole on the body to prevent lose when not in use.
- To protect the floor or the carpet from stains and sweat during workout, we recommend you to put a sheet or specially designed mat under the trainer and bike.
- If your bike is equipped with a hydraulic disc brake, be sure you don't pull the brake lever after removing the wheel. The pads will be stuck and you will not be able to install the wheel with rotor again.
We strongly recommend you to put a spacer between the pads as soon as you remove the wheel.
Minoura is not responsible to any trouble and accidents which were caused by the wrong setting or trouble on your brake system.
- Any warranty will be void if you use MD640 for any other purpose than instructed.
Minoura offers 1-year limited warranty on this product from the date of your purchase for any problem caused by manufacturer's defect.
Any damage or problem caused by transporting process or user's misuse, also the natural wear will not be covered under warranty.
Read the enclosed "Minoura Limited Warranty Policy" card for more details.
For the latest information, refer Minoura web site (<http://www.minoura.jp/english/>) regularly.

MD640 Contents

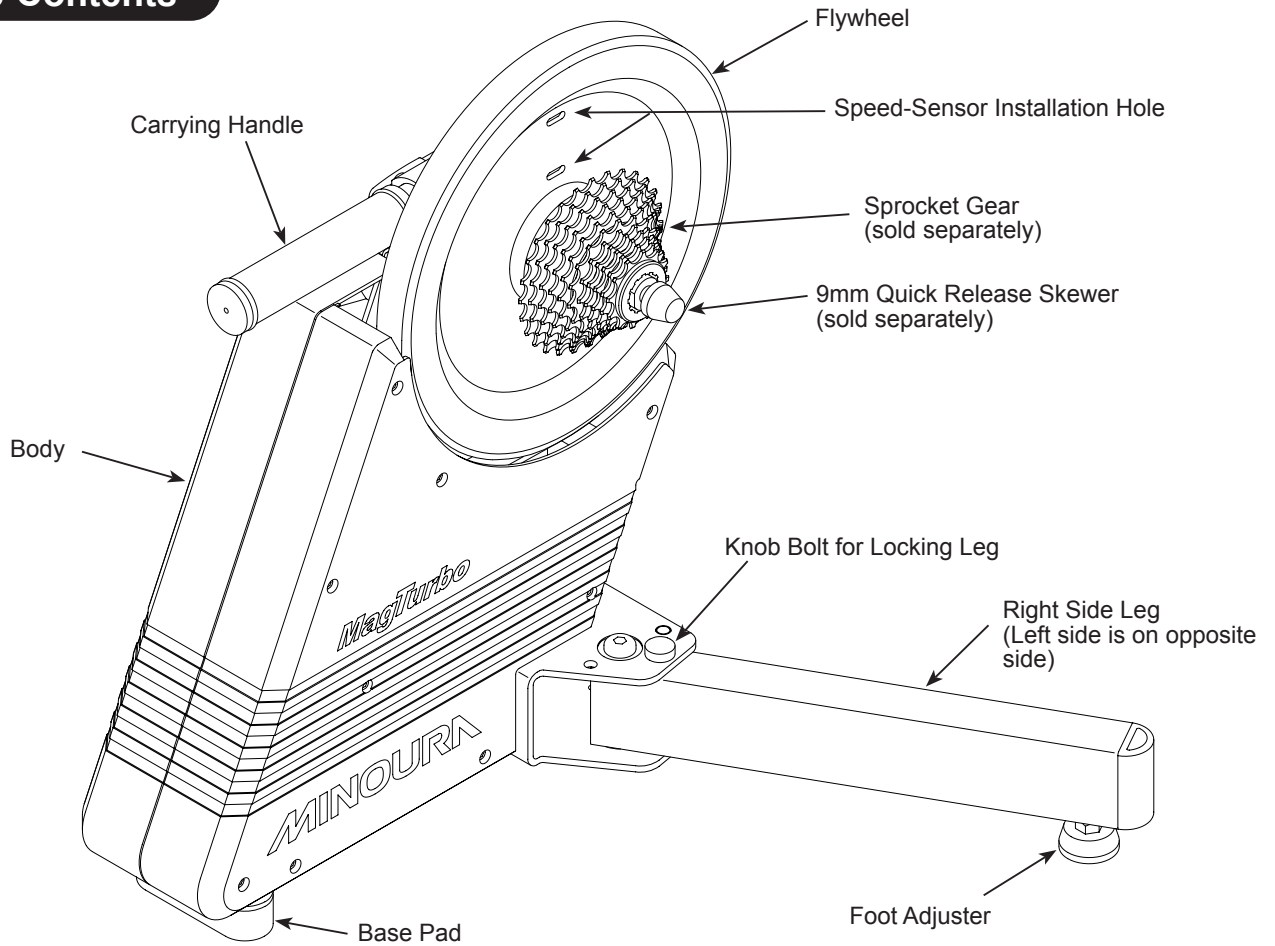

[Supplied Parts]

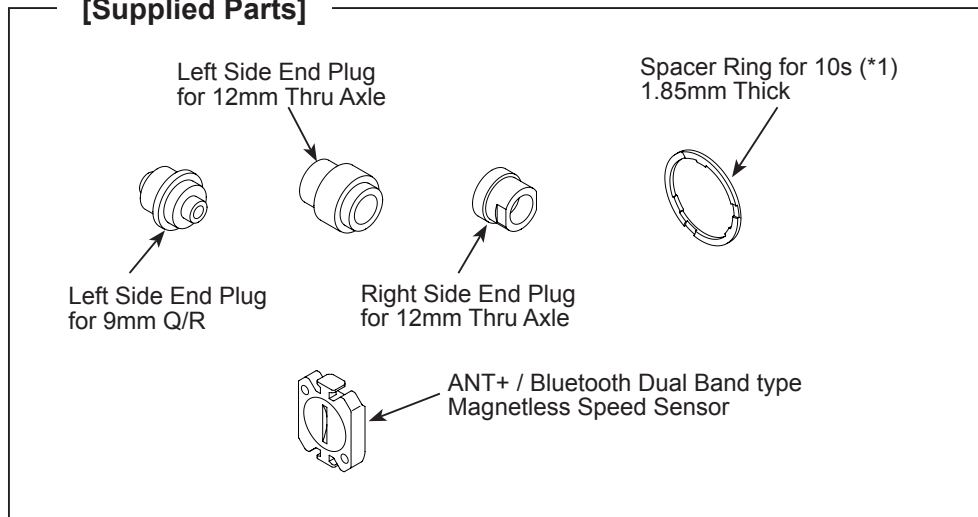

*1 You will use this ring only for 8s and 9s.
 On 10s, the 1.0mm thick spacer ring which is supplied with the Sprocket Gear too.
 (On CS-HG500, you will use the 1.85mm thick ring ONLY)

[Not Supplied]

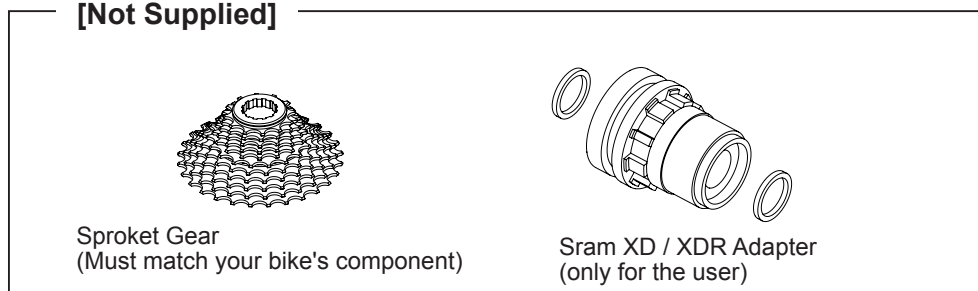

- 1** Place the MD640 on the floor.
Take the MD640 from the box and grab the Carrying Handle, then place it on the floor gently as the Flywheel faces upward. (see Fig. A)

 *This is a very heavy unit.
Be careful not to drop, or damage.*

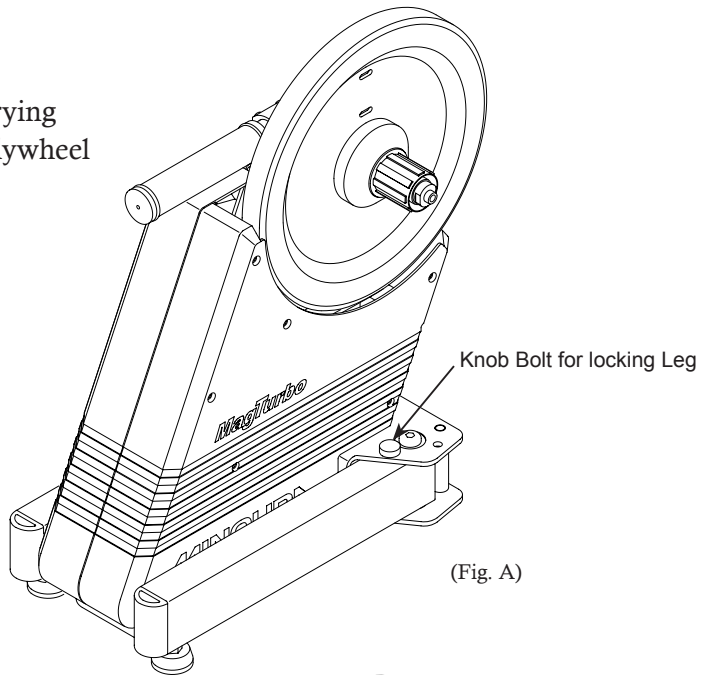

- 2** Remove the Knob Bolt.
Unscrew the knob bolt that locks the leg and remove.

- 3** Open the Right Side Leg and hold.
Turn the Right Side Leg to open. Insert the Knob Bolt into the hole for locking the open leg position, then tighten. (see Fig. B)

 *To close the leg, insert the knob bolt into the hole for closed leg position. This will prevent the Leg from opening unexpectedly.*

If you lose this knob bolt, you won't be able to lock the Leg.

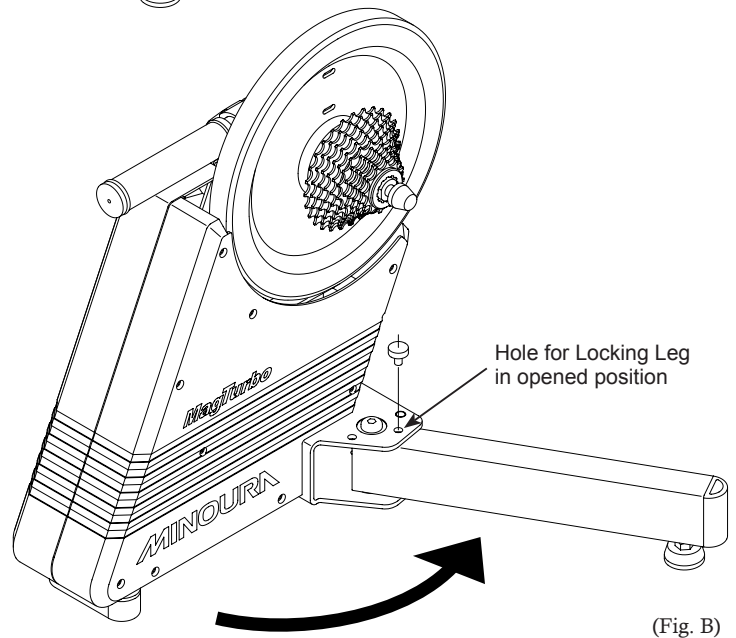

- 4** Open the Left Side Leg and hold.
Open the Left Side Leg as the right side, and hold it. (see Fig. C)

 *To transport the MD640, grab the Carrying Handle and support the Body with another hand.*

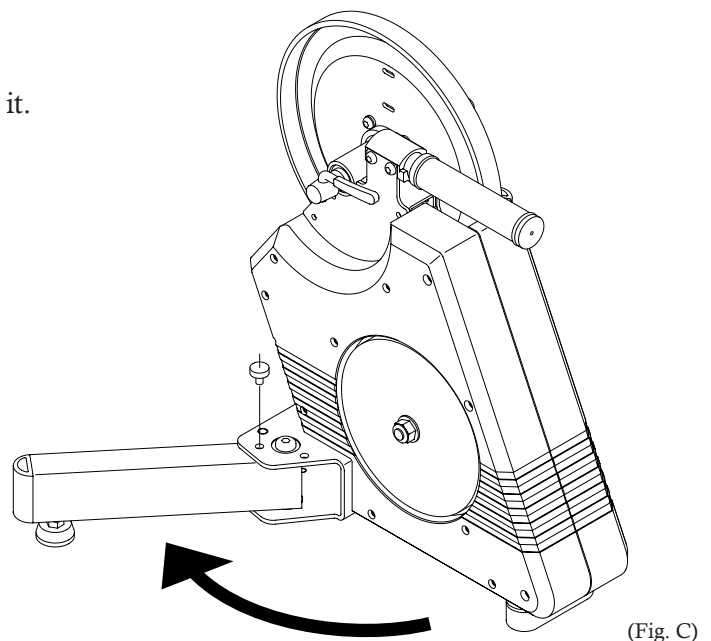

How To Install the Sprocket Gear

Required Tools (prepare separately)

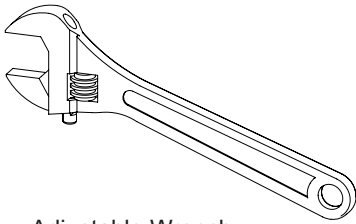

Adjustable Wrench
(Bigger one makes the job easier)



Lock Ring Tool
(for Shimano sprocket gear)

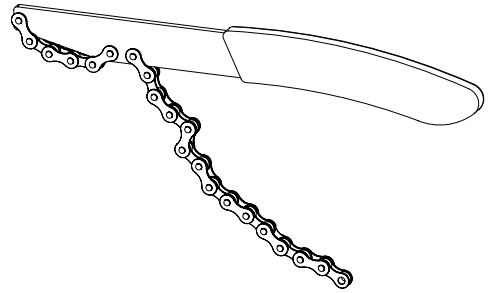

Sprocket Remover
(for removing the installed sprocket gear)

(Fig. D)

1

Install the Sprocket Gear

Insert the Sprocket Gear to the hub spline on the right side center of the Flywheel. (see Fig E)

Please note that only one of the splines is wider than others so the insertion point is limited.

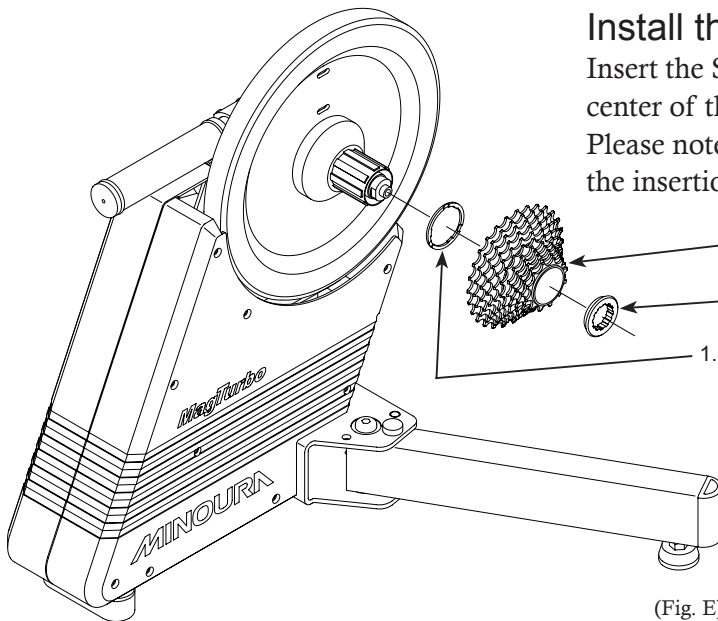

(Fig. E)

Sprocket Gear (not supplied)

Lock Ring (comes with the sprocket gear)

1.85mm Thick Spacer Ring (supplied)

(NOTE: You will use this ring ONLY on 8s and 9s.

On 10s, you also need to add the 1.0mm thick one, except with the CS-HG500.

You don't need to use on 11s, but some MTB gears may require it to adjust the total thickness.)

2

Tighten the Lock Ring.

Fully insert the Lock Ring Tool into the Lock Ring, and turn it clockwise by hand to install the Sprocket Gear to the Spline. Make sure you tighten it straightly, not angled.

After tightening it by hand, apply the Adjustable Wrench to the Lock Ring Tool and tighten more at 30 – 50 N.m torque to fix.

At this moment, hold the Flywheel by another hand not to allow to rotate together.

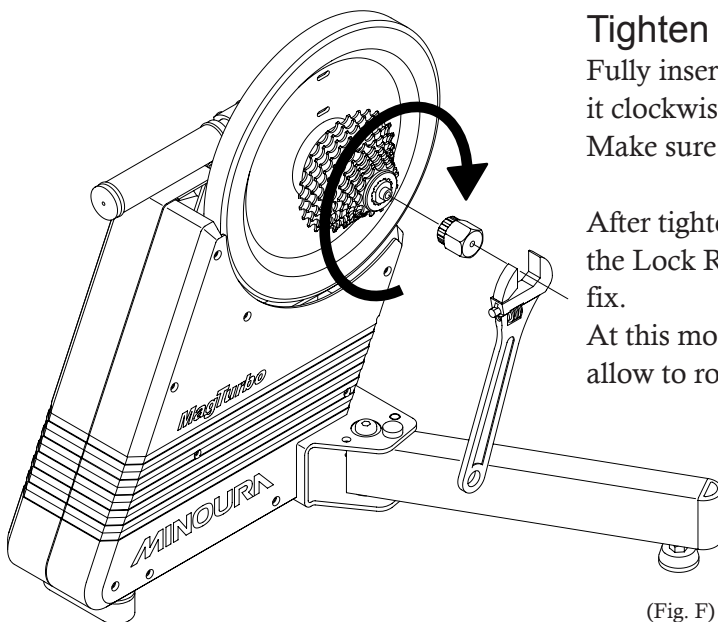

(Fig. F)

3

To use with the standard 9mm Quick Release Skewer, proceed to Page-8.

To use with the 12mm Thru Axle, follow to the next page.

How To Change To 12mm Thru Axle Hub

The MD640 has been designed to use with a standard 9mm Quick Release Skewer system. If your bike is equipped with the 12mm Thru Axle hub, you need to replace the Right Side End Plug on the tip of the hub to the one for Thru Axle system. (see Fig. G)

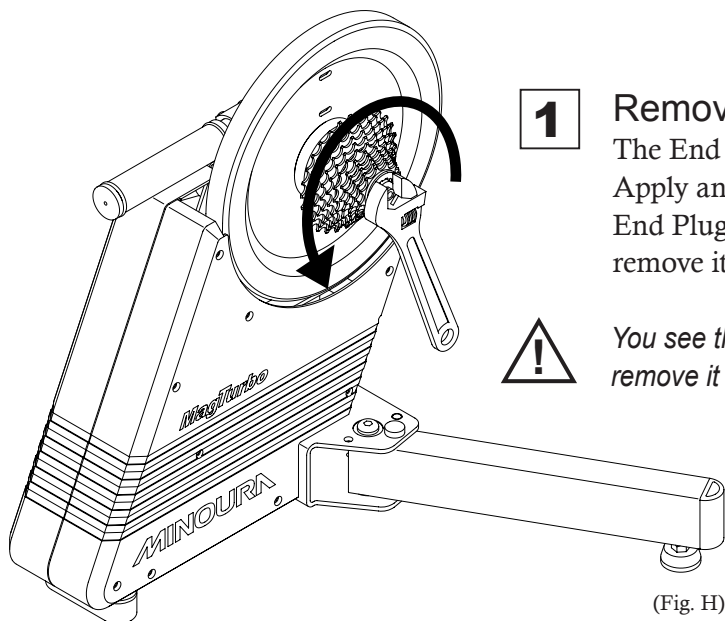
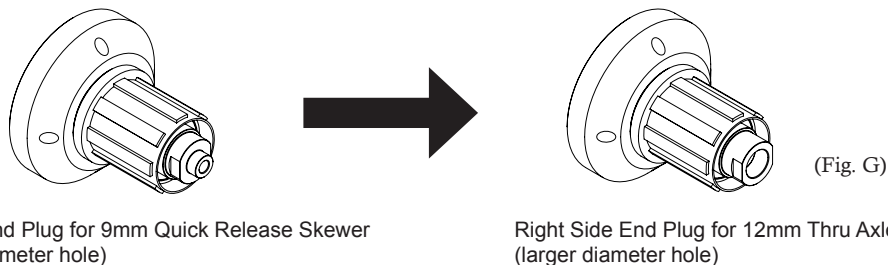

- 1** Remove the Right Side End Plug
The End Plug on tip of the hub is screwd in. Apply an adjustable wrench or a 17mm spanner to the End Plug and turn it counter-clockwise to loosen, then remove it by hand. (see Fig. H)

! You see the sprocket gear in fugure, but we recommend you to remove it before replacing the end plug.

- 2** Replace the End Plug
Install the supplied End Plug for the 12mm thru axle. Screw it into the hub by hand then tighten it with a spanner. (see Fig. I)

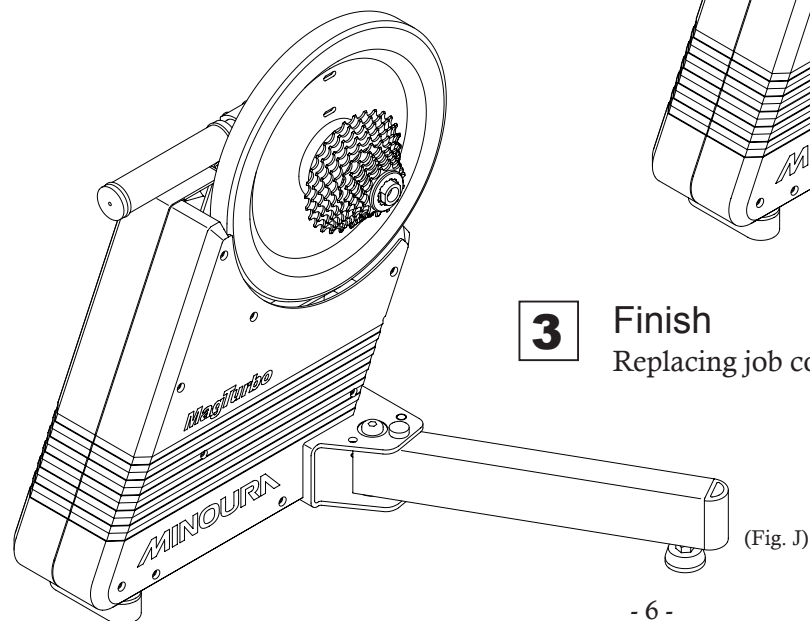
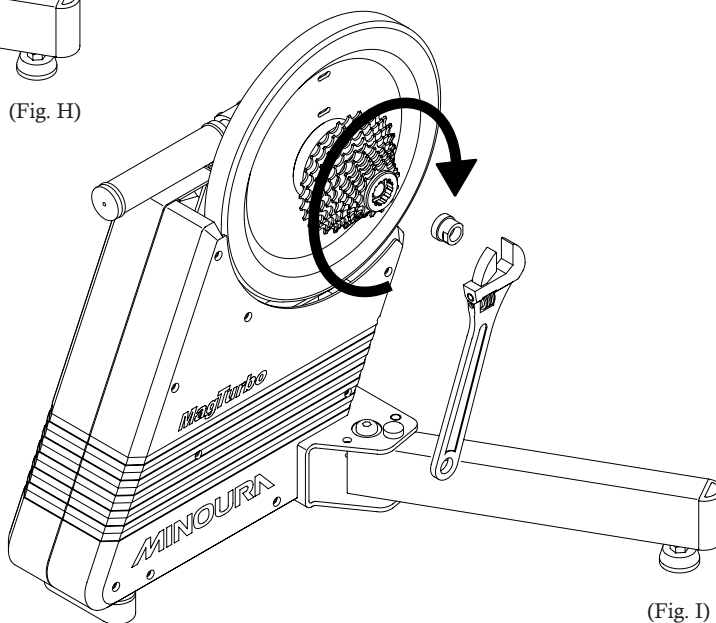

- 3** Finish
Replacing job completed. (see Fig. J)

About Left Side End Plug

The MD640 will fit the hub width 142mm and 148mm only on the 12mm thru axle system. Change the direction of the Left Side End Plug to match the size. (see Fig. K)

142mm : Insert from the longer sleeve side
148mm : Insert from the shorter sleeve side

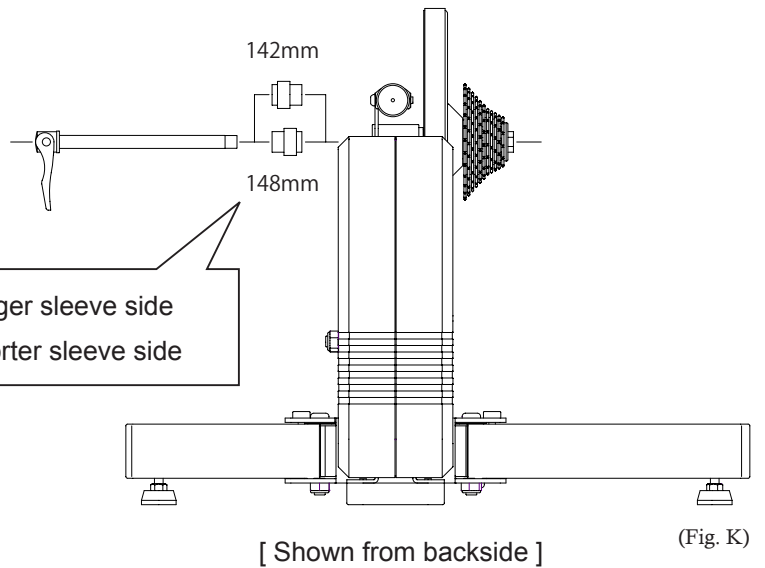

Bike Setup

1 Adjust the position

First, insert the wheel axle into left side hole of your bike frame rear end, then hold the bike as the drop-outs are located just above the MD640's wheel hub. (see Fig. L)

At this moment, we recommend you to shift the chain to the top position to make this job easier.

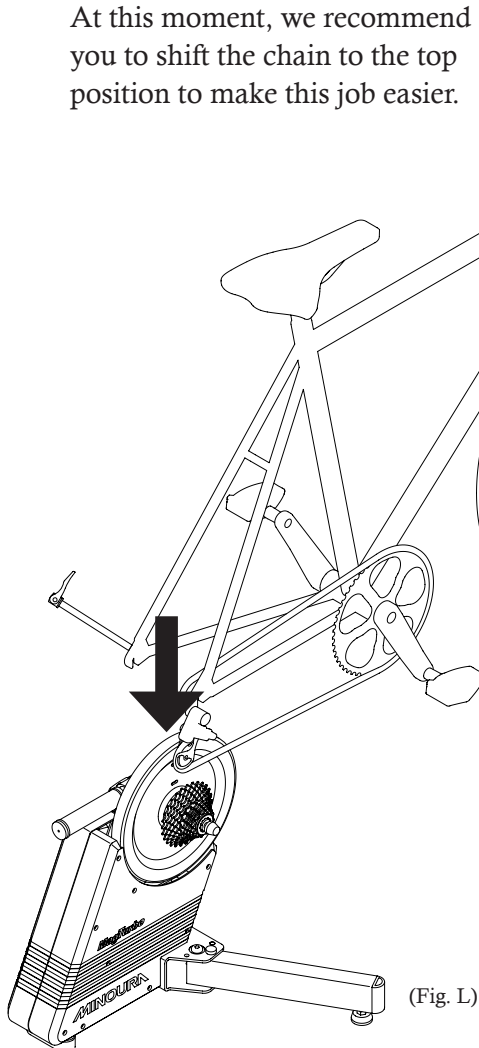

2 Fully insert the axle

Align the trainer hub hole and the bike's rear end, then insert the axle into the hub hole fully. (see Fig. M)
The bike position will be fixed in this step.

3 Fix the axle

Screw the axle toward the right side frame end threaded hole. If your axle is a quick release type, adjust tightening and close the lever to fix firmly.

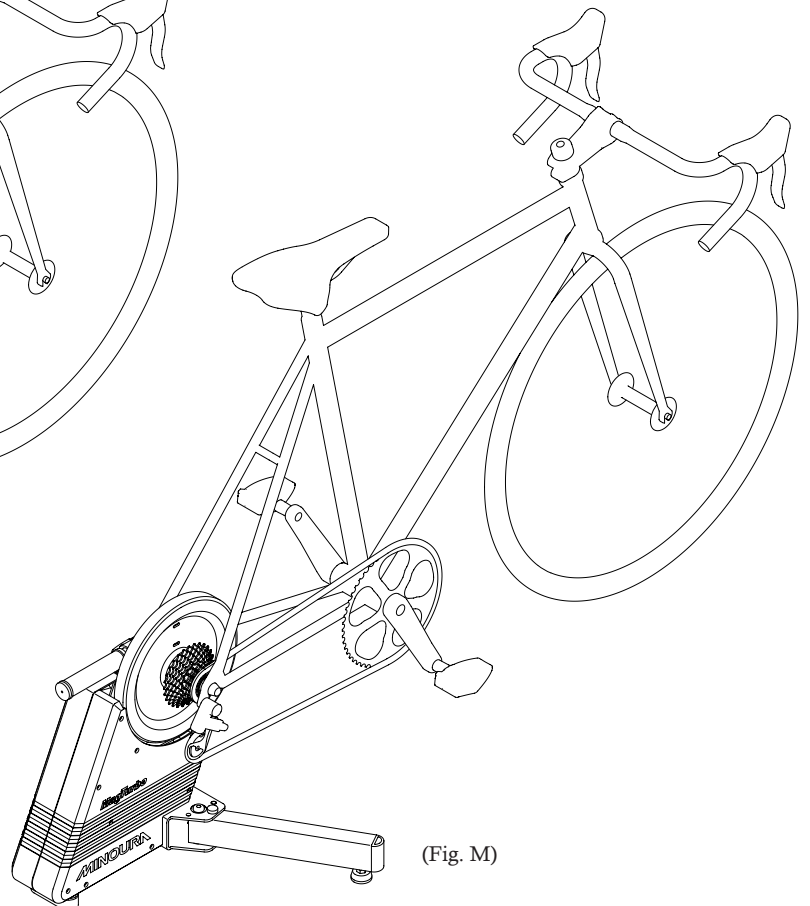

For 9mm Quick Release Skewer

How To Install the Q/R Skewer

Your MD640 is set for a 9mm quick release skewer, so you don't need to replace the Right Side End Plug. (see Fig. H on page-6)

Insert the supplied Left Side End Plug for 9mm Q/R into the left side hole of the hub. (see Fig. O)

Disassemble the skewer, set an Acorn Spring into the shaft, insert it from the left side hole of the hub.

Set the other Acorn Spring into the projected shaft, and tighten the nut. (see Fig. N)

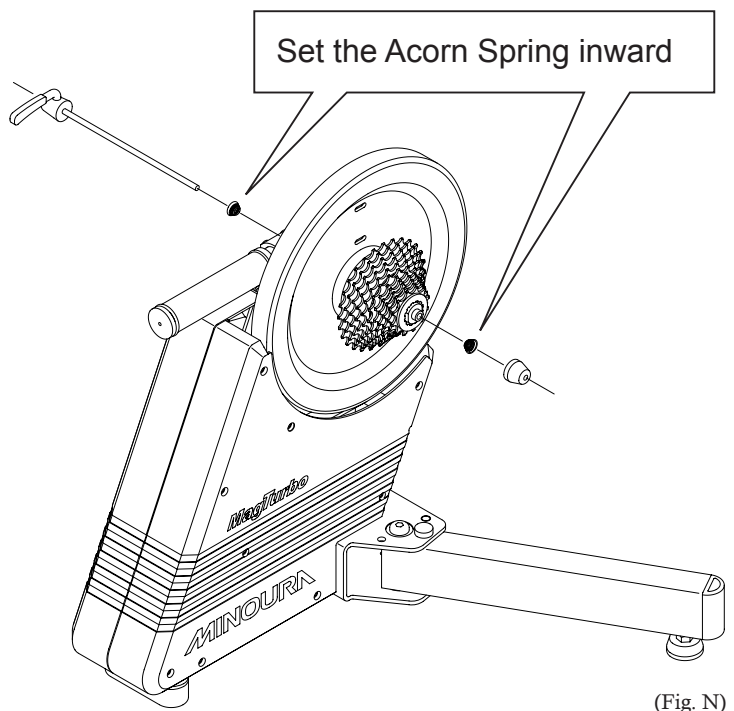

About Left Side End Plug

The MD640 will fit the hub width 130mm and 135mm only on the 9mm quick release skewer system.

Change the direction of the Left Side End Plug to match the size. (see Fig. O)

130mm : Insert from the longer sleeve side
135mm : Insert from the shorter sleeve side

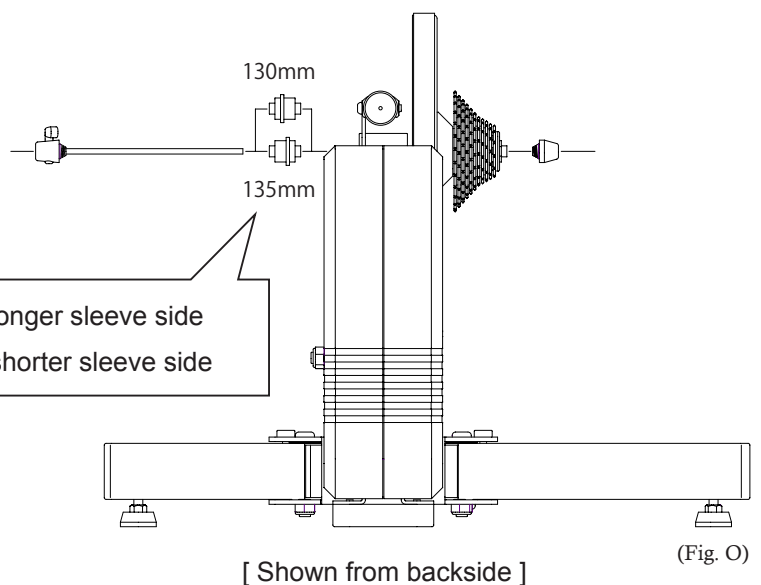

Bike Setup

- 1** Open the quick release skewer lever
Fully open the lever of the quick release skewer.
- 2** Change the chain position
To make installing the bike on MD640 easier, shift the chain to the top position.
- 3** Hook the chain to the top gear
Set the chain to the top gear of the sprocket as same as reinstalling the rear wheel to the bike usually, and set the frame end onto the hub. (see Fig. P)
- 4** Close the skewer lever
After confirming that the bike frame is fully inserted into the hub and the bike frame stands vertically, hold the bike firmly by closing the quick release skewer lever after adjusting the nut tightening. (see Fig. Q)

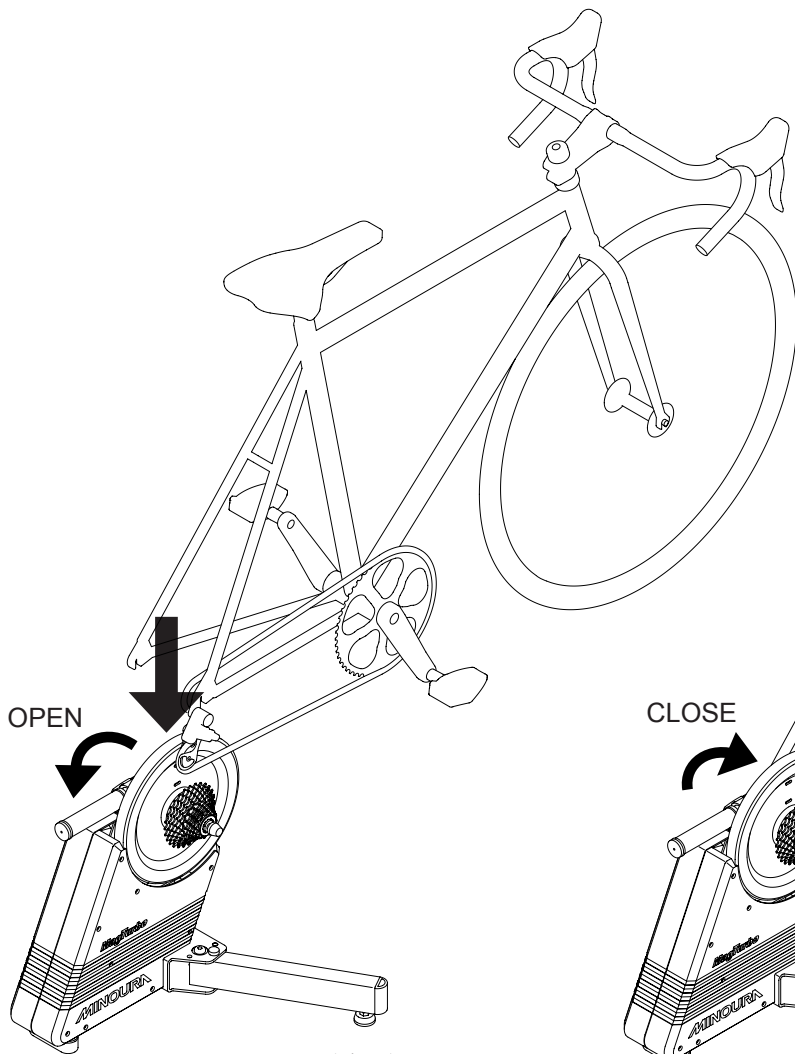

(Fig. P)

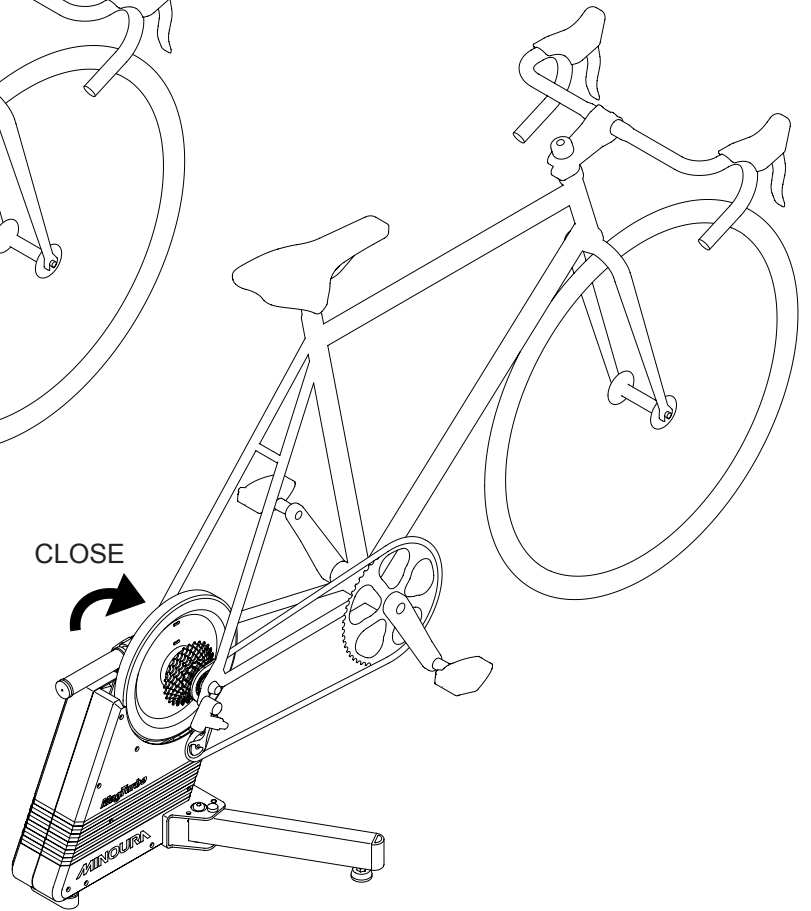

(Fig. Q)



If you have quick release skewer questions, ask a skilled mechanic how to operate the Q/R skewer correctly.

How To Remove the Sprocket Gear

When you need to remove the sprocket gear for some reason as changing components, you will need a special tool called as Sprocket Remover as well as well as the Lock Ring Tool.

Apply the chain of the Sprocket Remover to the larger gear as shown in Fig. R. This works as it prevents rotating the gear together with the hub.

Fully insert the Lock Ring Tool to the Lock Ring, apply an adjustable wrench on it, then turn them in opposite directions of each other. Turn the wrench counter-clockwise and turn the Sprocket Remover clockwise.

Then the Lock Ring will be loosened.

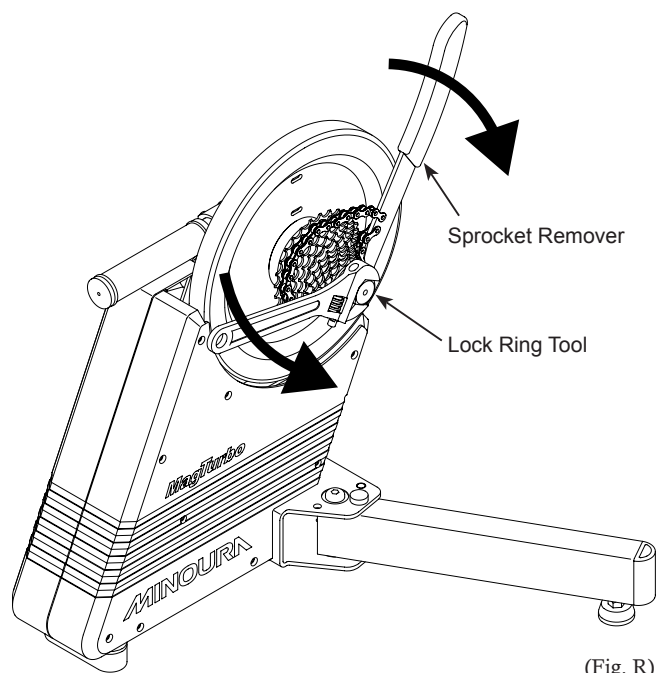

(Fig. R)

How To Adjust Foot Adjuster

Required Tool : 13mm Spanner

You need to precisely adjust the length of each Foot Adjuster in order to set the bike vertically correctly and with correct stability. (see Fig. S)

Turn the adjuster to change its length, screw the nut toward the leg, and tighten it firmly using a 13mm spanner. (See Fig. T)

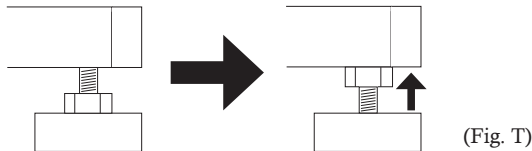

! *If you don't use the Foot Adjusters correctly, the bike will lose stability and may present a danger.*

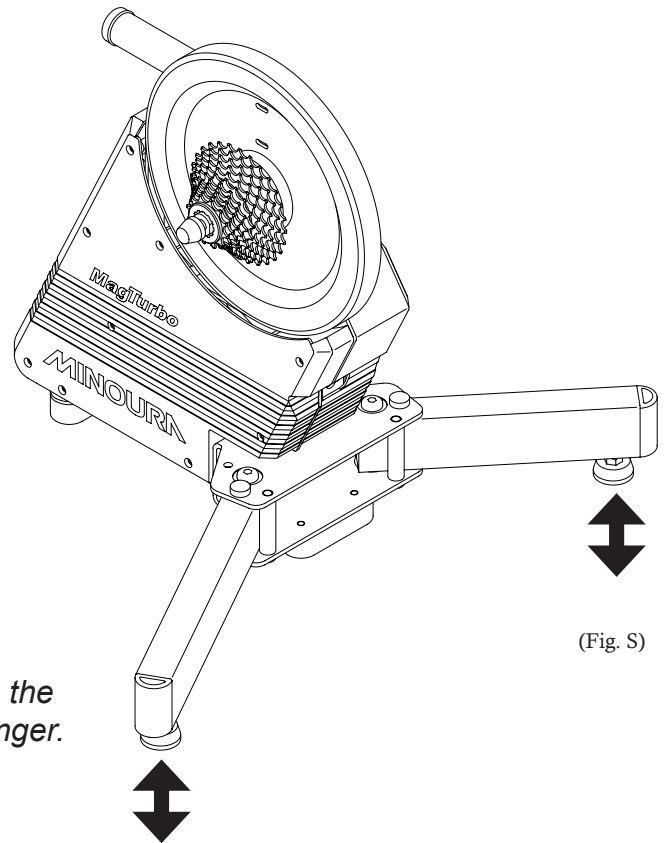

How To Use the Remote Shifter

Required Tool : 4mm Hex Wrench

The MD640 is equipped with a convenient Remote Shifter that allows you to change the resistance power by 13 levels. (The top panel shows just 7 positions, but there is another position between the numbers.)

Install the Remote Shifter onto the handlebar or stem, then you can change the power without getting off the bike.

The clamp band is made of flexible plastic, so it will fit not only the round dimension handlebar but aerodynamic bar or round shape stems, too.

How To Clamp Remote Shifter :

- 1) Wind the plastic band around the handlebar or stem.
- 2) Hook the band tip to the groove on the shifter base. (see Fig. U-1)
- 3) Pull up the Lock Lever to tighten the band. (see Fig. U-2) (If you need to adjust the band length before clamping, follow instructions on the next page.)

Increase Power : Turn the shifter dial to increase the number (toward H symbol)

Decrease Power : Turn the shifter dial to decrease the number (toward L symbol)

! *You can set the shifter between 1 and 7 levels only.*

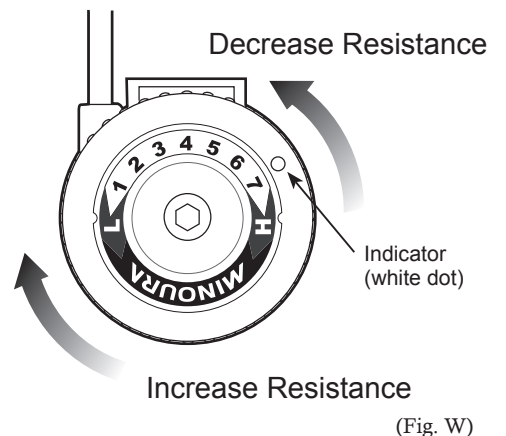
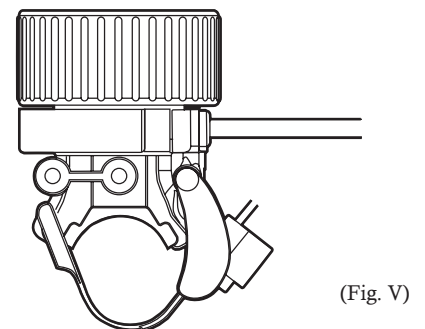
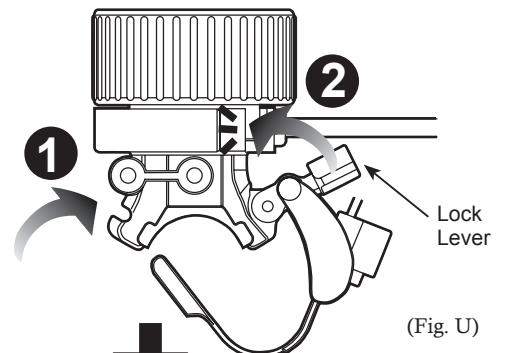

The remote shifters clamping band may be too tight or too loose to depending on your handkebar size.

And also it's too tight for mounting on a stem.

To solve this problem, the clamp band has an adjustable mechanism that rotates the worm gear. (see Fig. X)

Insert a 4mm hex wrench (not supplied in the kit) to the plastic gear and rotate to adjust.



Do NOT force to over-tighten the plastic worm gear, and remove the band from the hook on the shifter base before adjusting.

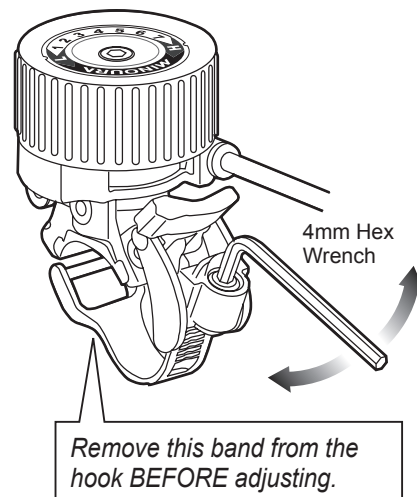

(Fig. X)

How To Adjust the Shifter Cable

Required Tool : 8mm Spanner

If you are not able to set the remote shifter lever at the far point such as 1 or 7 due to too tight or too loose a cable, it's time to adjust the cable tension. Do it by changing the Lock Nut position as follows. (see Fig. Z and AA)

1 Lay the remote cable on the floor

Remove the Remote Shifter from the handlebar, lay the remote cable on the floor as straight as possible, then set the shifter at 7 (that is the loosest condition).

2 Screw the Adjusting Bolt toward the cable

While pushing the Remote Cable toward the shifter, screw the Adjusting Bolt counter-clockwise. This will make the bolt further from the unit housing and it will be forwarded to the cable. (see Fig. Z)

At this moment, you will see some gap between the bolt and the housing. Making it a zero gap is the purpose of this job.

3 Tighten the Lock Nut toward housing

When the nut reaches the housing, tighten more with an 8mm spanner to fix the position. (see Fig. AA)

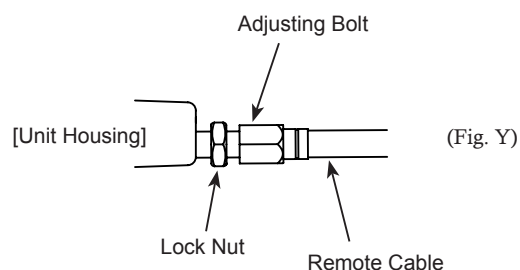

(Fig. Y)

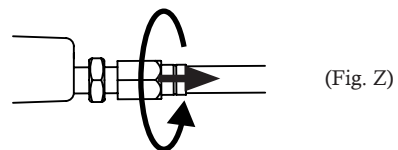

(Fig. Z)

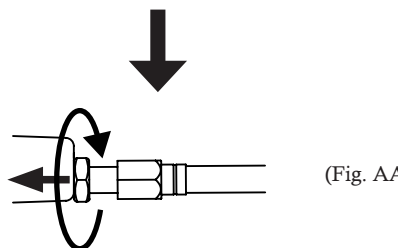

(Fig. AA)

Performance of Each Remote Shifter Zone

①~③ Fitness

Low Resistance

For warming up and cooling down.

Good for light level exercise.

③~⑤ Exercise

Mid Resistance

Each step has different resistance power.

Good for interval training or aerobic training that changes the power step by step.

⑤~⑦ Training

High Resistance

Good for anaerobic exercise or hard training simulating hill climbing.

About Wireless Speed Sensor

The MD640 is NOT a Smart Trainer so it is impossible to change the resistance power automatically depending on the virtual courses. However, a very useful Speed Sensor comes in the kit that transmits the current speed data to a cycle-computer or PC via ANT+ & Bluetooth Dual Band transmitter. (see Fig. AB)

This sensor is equipped with a very unique mechanism that doesn't require any magnet on the bike side to pickup the signal. Follow the steps below to install;

- 1** Twist and open the back side cap by a coin, and confirm if the button type battery (CR2032) is set inside correctly. (see Fig. AB)
The battery is isolated by a film to prevent draining. Remove the film.

- 2** This sensor has two modes; speed and cadence, but we will use the speed mode only.
The mode can be switched between speed and cadence by inserting/removing the battery then the front side LED color will be changed.

- RED — Speed Sensor Mode
- × BLUE — Cadence Sensor Mode

If the light is **blue**, it means the sensor is set as a **cadence** mode, so you need to remove and reinstall the button battery to change the mode.
After a few seconds, the light will be changed to **red** that means the sensor has been set as the **speed** mode.

To set the cap again, make sure you align the triangle marking on the cap and one of two dots, otherwise the cap cannot be set correctly. (see Fig. AB)

- 3** Attach the Backside Protector onto the Sensor. (see Fig. AC)
There are two different types of protector in the kit; a thin and flat one, and a thick and bent one. You will use the thinner protector only.
Insert two projections into the holes on the sensor.
- 4** There are two rectangle holes on the Flywheel for the Sensor. Install the Sensor on the right (sprocket gear) side (see Fig. AD). Opposite side could cause error while transmitting.
Put the Rubber Ring through this hole and hook the Sensor.
There are two sizes of rubber rings in the kit; small and large. You will use the smaller one only.
When installing the Sensor, make sure if the Sensor is tightly mounted on the Flywheel. If it is unstable, the Sensor may not work properly.

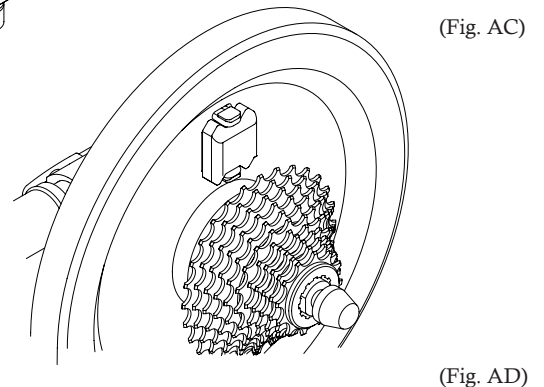
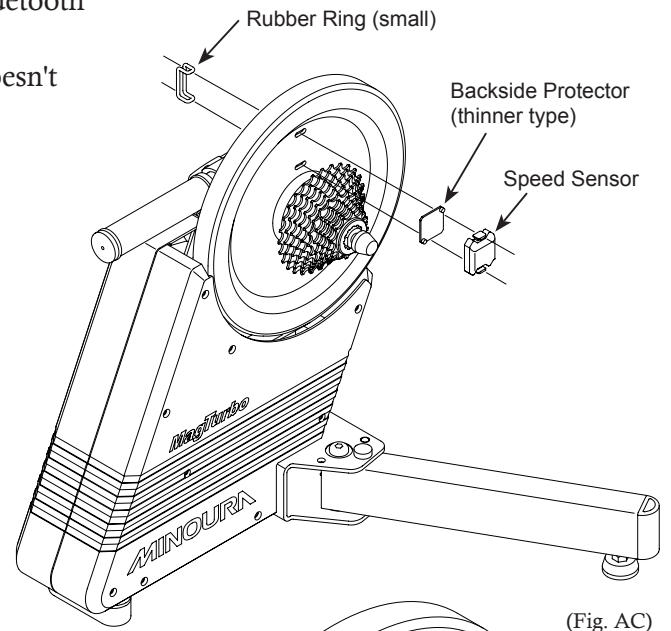
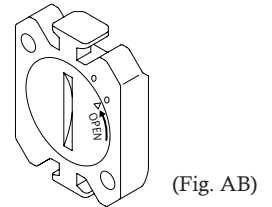

Be careful not to hurt your finger by the sprocket gear when installing the sensor.



This sensor has dual transmitting mode; ANT+ and Bluetooth.



Bluetooth can be connected to your smart-phone or tablet easily in its standard function. To use ANT+ mode, you will need a special ANT+ Receiver sold separately.