

REAR FENDER

“OODACHI” is the series name of the longer version of Minoura’s **DYK**-series bicycle fender (mudguard). (The shorter version is called “KODACHI”)
 Standard fenders are usually made of plastic, which is difficult to recycle and harmful to the environment. In contrast, Minoura’s DYK-series fenders are made only from the materials that are easy to recycle, such as stainless steel and light alloy.

Schematics

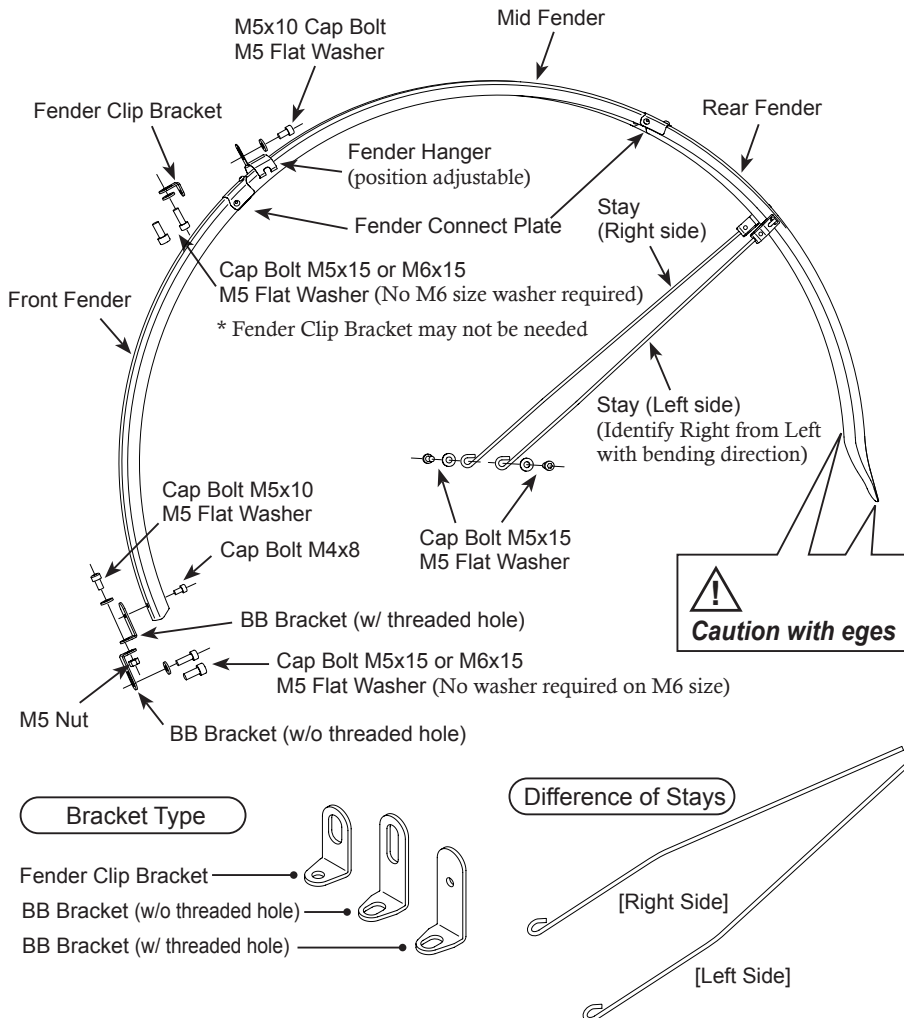

Applicable Wheel Size

26 - 28 inch / 650c - 700c

Fender Width

47mm (max tire width is 45mm)

Contents

[Body Side]

Front & Mid Fender 2
Rear Fender 1
Stay (Right & Left side) 1 each
Fender Clamp Base, Back Plate, Headless Bolt M4x3 2 each
Cap Bolt M4x8 2

[Parts Bag #1]

Fender Connect Plate (Inner & Outer side) 2
Fender Hanger 1
Rubber Sheet (22x55mm) 1
Fender Clip Bracket 1
BB Bracket (w/, w/o thread) 1 each
M4x8 Cap Bolt 1
M5x10 Cap Bolt 2
M5x15 Cap Bolt 4
M6x15 Cap Bolt 2
M5 Flat Washer 6
M5 Nut 1

[Parts Bag #2]

2mm Hex Wrench (for M4 Headless Bolt)
3 mm Hex Wrench (for M4 Cap Bolt)
4 mm Hex Wrench (for M5 Cap Bolt)

Caution on Installation & Dairy Use

- This product is positioned very close to the fast-spinning wheel. If it is not installed properly, it may be dangerous and could get caught in the wheel. We strongly recommend having this product installed by a well-trained and experienced mechanic or at a bike shop. Minoura will not be responsible for any damage or injury resulting from improper installation.
- Check that all bolts are properly tightened each time you use this product.
- Make sure no part of your bike or your body (especially your heels) comes into contact with the fender before you start riding.
- When you need to cut the stay to adjust its length, use a proper tool such as a clipper. You cannot cut the stainless-steel rod with standard nippers or pliers.
- Be aware that the tip of the Stay is very sharp and may cause injury. Grind the tip for your safety. Do NOT use a standard file, as the stainless steel material is very hard.
- If you notice any unusual sound or vibration from the fender while using it, stop immediately and contact the shop where it was installed.
- This product may not fit certain bike frames due to special frame designs or dimensions.

Contact

MINOURA JAPAN 134-1 Shimomiya, Godo, Anpachi, Gifu 503-2312 Japan

Email minoura@minoura.jp **Web** www.minoura.jp

Made in Japan

Preparation

There are two types of fenders: one with a lip and two without lips. The two fenders of the same type will be used for the Front and Mid after being connected to each other.

① First, connect the Front and Mid fenders.

The Mid Fender is pre-assembled with the Fender Connect Plates in the kit. Loosen two button bolts that are located on both side, and remove the center bolt. (see Fig. A)

Insert the Rear Fender into the clearance between the fender and the plate, then tighten and install all bolts to connect (see Fig. B).

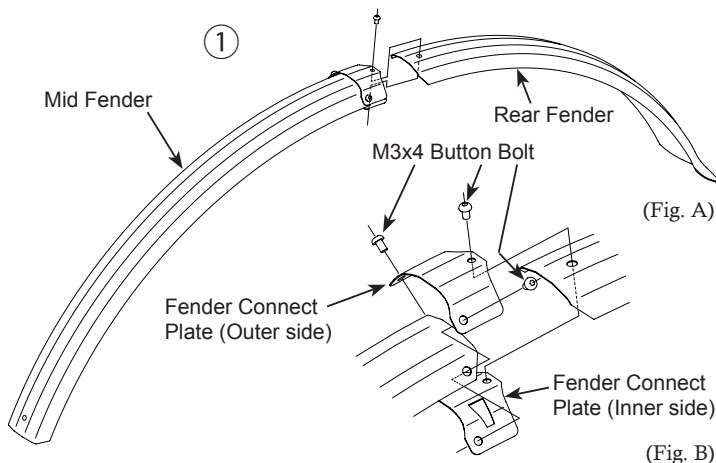

② After that, connect the Front Fender to them as well.

Installation

Two different installations are available. Choose the appropriate one to your bike frame type.

[Install onto the caliper brake]

Put the brake axle into the bracket hole and hold them together to the frame.

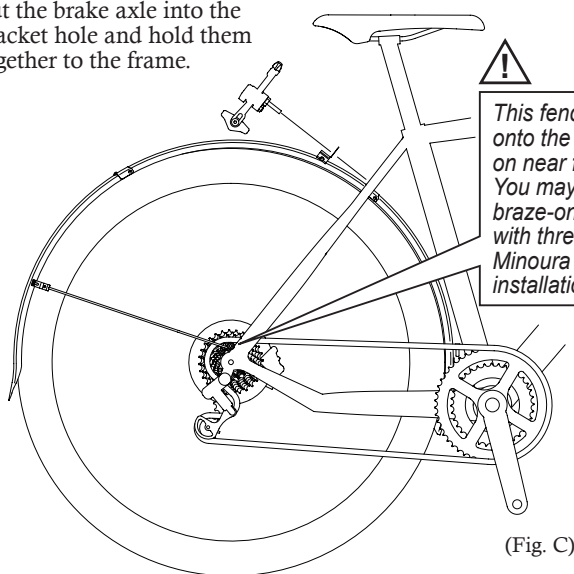

(Fig. C)

[Install to the seatstay bridge (disc brake bike)]

Install the bracket directly to the seat-stay bridge then install the fender via a small bracket.

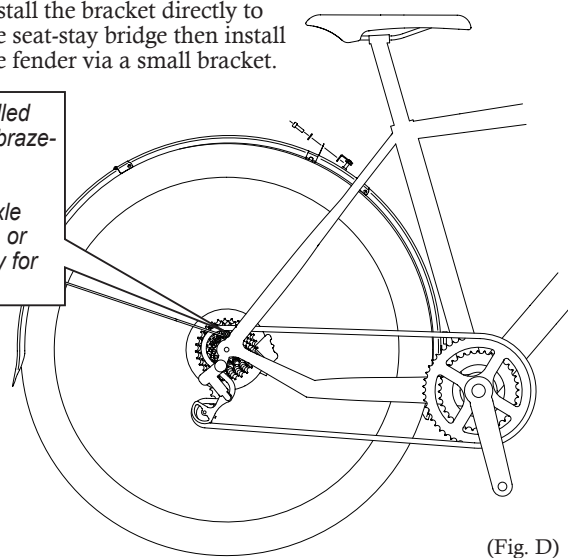

(Fig. D)

How To Install

① [Common on both caliper brake and seatstay bridge]

First, remove the rear wheel for easier job in the later steps.

Install the front end of the fender into the hole located on the frame bridge just behind the bottom bracket. Depending on the direction the hole faces (vertical or horizontal), follow the appropriate installation method.

② [To Install to the Backside Hole on the Bridge]

Install the BB Bracket (w/ thread hole) to the front end of the fender. Attach the BB Bracket (w/o thread) to it, then install it to the hole behind the seat-stay bridge. (see Fig. E & G)

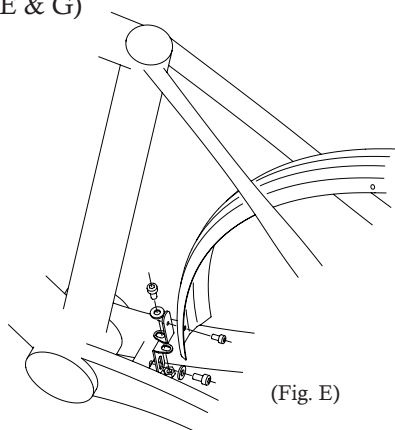

(Fig. E)

[To Install to the Top Hole on the Bridge]

Install the BB Bracket (w/ thread hole) to the front end of the fender, then install it to the top hole on the seat-stay bridge (see Fig. F & H). You will NOT use the BB Bracket (w/o thread).

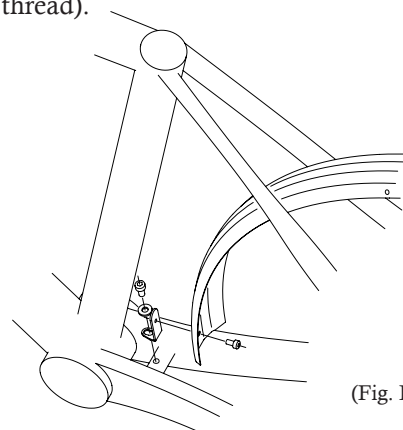

(Fig. F)

[To Install to the Backside Hole on the Bridge]

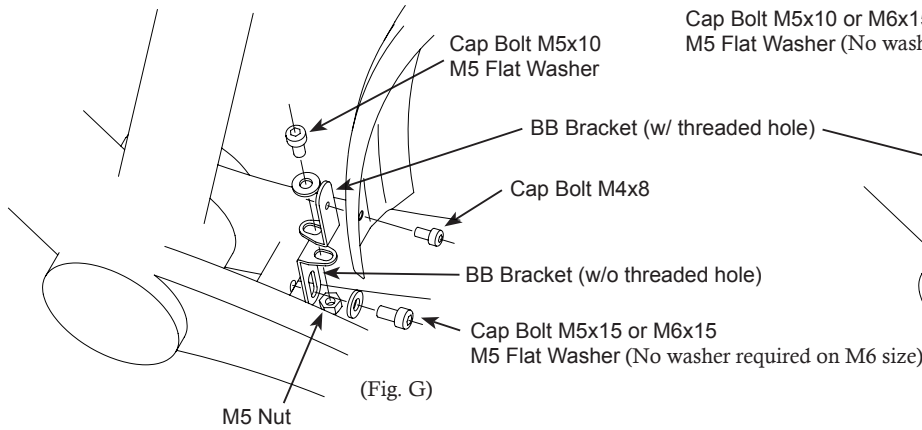

[To Install to the Top Hole on the Bridge]

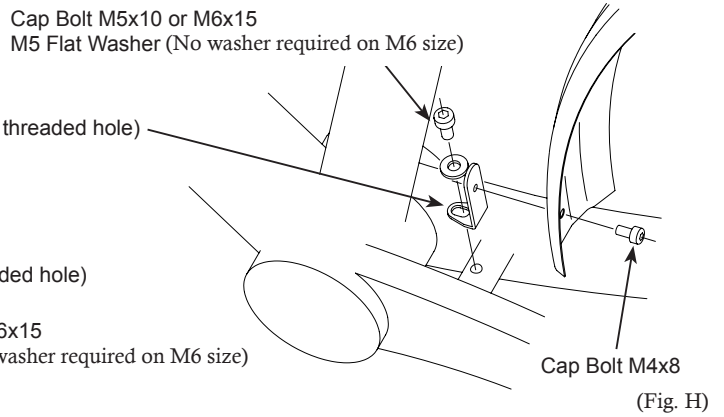

! *In either case, if you cannot install the BB Bracket correctly with the supplied bolt and you need another longer bolt and nut, please prepare them yourself.*

[Install onto the caliper brake]

- ③ Remove the rear caliper brake.
- ④ Put the Fender Hanger through the brake pivot shaft, and install the brake to the bike frame again. Make sure the brake arms are not obstructed by the bracket and that they move smoothly (see Fig. C).

[Install to the seatstay bridge (disc brake bike)]

- ③ Attach the Fender Hanger to the seat-stay bridge on your bike with the supplied M5x10 Cap Bolt and M5 Flat Washer.
- ④ If the hole on the bridge faces downward, attach the Fender Clip Bracket to the bridge first, then set the Fender Hanger on it later (see Fig. D).

[Followings are common on both caliper brake and seatstay bridge]

- ⑤ Attach the fender into the Fender Hanger from the bottom. This bracket holds the fender in position. Beware that the front end of the fender is fixed to the frame, so you cannot move the fender position back and forth.

Put the Rubber Sheet under the fender where the bracket sits. Bend all 4 tangs of the bracket inward to catch the fender, then inserting them into the rubber sheet (see Fig. I).

! *Fix the fender position precisely so that the fender and the base do not touch the spinning wheel while riding. If the fender becomes caught in the wheel during a ride, it can be extremely dangerous and may cause you to fall off the bike.*

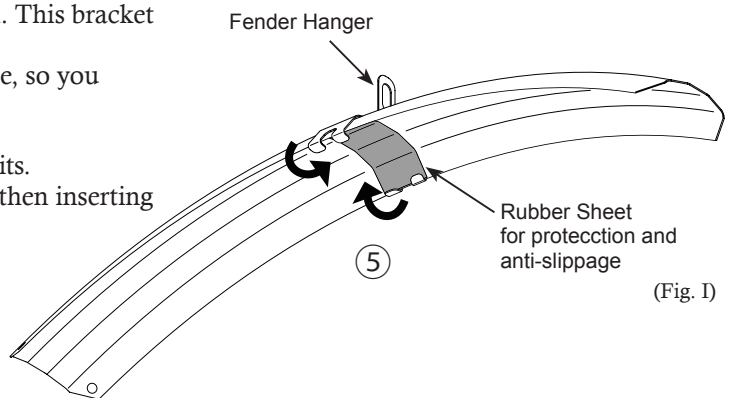

! *When bending the tang, use a plier with Vinyl tape on the jaws to avoid scratches.*

! *Beware that the fender is made of sturdy but easy-to-be-scratched material. Handle with care.*

- ⑥ You securely hold the rear part of the fender with the supplied stays to avoid unexpected shaking caused by vibration during ride. Set back the rear wheel onto the bike. Place the rounded end of the stay to the braze-on near rear wheel axle and temporarily hold it with the M5x15 Cap Bolts and Flat Washers. (see Fig. C)
- ⑦ To catch the fender, direct the Stay backward. Set the Fender Clamp Base and the Back Plate in the middle of the Rear Fender, then seurely tighten them by the M4x8 Cap Bolt. Remove the bolts on the braze-on to make the stays free. Insert the straight side Stay tip into the hole under the base (see Fig. C & J).
- ⑧ Adjust the clearance between the fender and the tire by telescoping the Stay, and secure it by tightening the headless bolt M4x3 (see Fig. K).

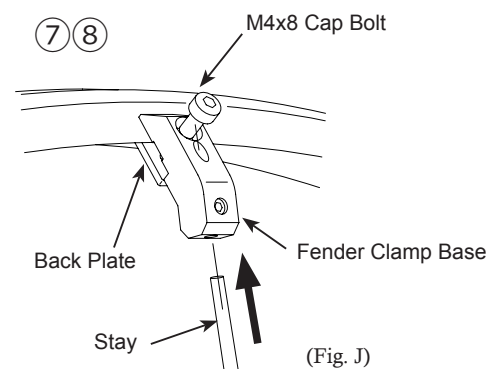

- ⑨ At this stage, it can be dangerous if the Stay comes out of the hole or is left secured. To prevent this, cut the Stay so that it can not come out of the fender (see Fig. L).

Mark the cut line with a felt pen, and cut it after removing from the clamp base.

Since it is difficult to cut the Stay while it is attached to the base, we recommend removing it first, cutting it, and then reinstalling it.

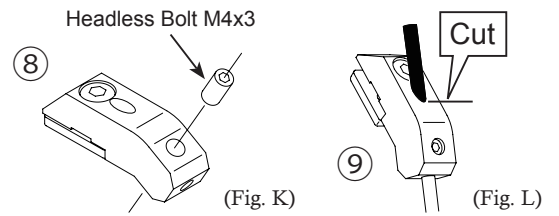

Set the positions of the fender and Clamp Base properly so they do not interfere with the spinning wheel or tire. If the fender gets caught in the wheel while riding, it may cause a sudden stop and could result in an injury.



Simply cutting the Stay can still be dangerous because the cut surface is very sharp. Grind it for your safety. It may be difficult to do this with a file due to the Stay's very hard material.

- ⑩ Finally, tighten all bolts firmly. Now you are ready to go out.

